

1260 VXI SWITCHING CARD

1260-162 A/B RF TRANSFER SWITCH PLUG-IN

PUBLICATION NO. 980824-162

RACAL INSTRUMENTS

Racal Instruments, Inc.

4 Goodyear St., Irvine, CA 92618-2002
Tel: (800) RACAL-ATE, (800) 722-2528, (949) 859-8999; FAX: (949) 859-7139

Racal Instruments, Ltd.

480 Bath Road, Slough, Berkshire, SL1 6BE, United Kingdom
Tel: +44 (0) 1628 604455; FAX: +44 (0) 1628 662017

Racal Systems Electronique S.A.

18 Avenue Dutartre, 78150 LeChesnay, France
Tel: +33 (1) 3923 2222; FAX: +33 (1) 3923 2225

Racal Systems Elettronica s.r.l.

Strada 2-Palazzo C4, 20090 Milanofiori Assago, Milan, Italy
Tel: +39 (0)2 5750 1796; FAX +39 (0)2 5750 1828

Racal Elektronik System GmbH.

Technologiepark Bergisch Gladbach, Friedrich-Ebert-Strasse, D-51429 Bergisch Gladbach, Germany
Tel: +49 2204 8442 00; FAX: +49 2204 8442 19

Racal Australia Pty. Ltd.

3 Powells Road, Brookvale, NSW 2100, Australia
Tel: +612 9936 7000, FAX: +612 9936 7036

Racal Electronics Pte. Ltd.

26 Ayer Rajah Crescent, 04-06/07 Ayer Rajah Industrial Estate, Singapore 0513.
Tel: +65 7792200, FAX: +65 7785400

Racal Instruments, Ltd.

Unit 5, 25F., Mega Trade Center, No 1, Mei Wan Road, Tsuen Wan, Hong Kong, PRC
Tel: +852 2405 5500, FAX: +852 2416 4335

<http://www.racalstruments.com>



PUBLICATION DATE: November 13, 2001

Copyright© 2001 by Racal Instruments, Inc. Printed in the United States of America. All rights reserved.
This book or parts thereof may not be reproduced in any form without written permission of the publisher.

WARRANTY STATEMENT

All Racal Instruments, Inc. products are designed and manufactured to exacting standards and in full conformance to Racal's ISO 9001 procedures.

For the specific terms of your standard warranty, or optional extended warranty or service agreement, contact your Racal customer service advisor. Please have the following information available to facilitate service.

1. Product serial number
2. Product model number
3. Your company and contact information

You may contact your customer service advisor by:

E-Mail:	Helpdesk@racalstruments.com		
Telephone:	+1 800 722 3262		(USA)
	+44(0) 8706 080134		(UK)
	+852 2405 5500	(Hong Kong)	
Fax:	+1 949 859 7309		(USA)
	+44(0) 1628 662017		(UK)
	+852 2416 4335	(Hong Kong)	

RETURN of PRODUCT

Authorization is required from Racal Instruments before you send us your product for service or calibration. Call your nearest Racal Instruments support facility. A list is located on the last page of this manual. If you are unsure where to call, contact Racal Instruments, Inc. Customer Support Department in Irvine, California, USA at 1-800-722-3262 or 1-949-859-8999 or via fax at 1-949-859-7139. We can be reached at: helpdesk@racalstruments.com.

PROPRIETARY NOTICE

This document and the technical data herein disclosed, are proprietary to Racal Instruments, and shall not, without express written permission of Racal Instruments, be used, in whole or in part to solicit quotations from a competitive source or used for manufacture by anyone other than Racal Instruments. The information herein has been developed at private expense, and may only be used for operation and maintenance reference purposes or for purposes of engineering evaluation and incorporation into technical specifications and other documents which specify procurement of products from Racal Instruments.

FOR YOUR SAFETY

Before undertaking any troubleshooting, maintenance or exploratory procedure, read carefully the **WARNINGS** and **CAUTION** notices.



This equipment contains voltage hazardous to human life and safety, and is capable of inflicting personal injury.



If this instrument is to be powered from the AC line (mains) through an autotransformer, ensure the common connector is connected to the neutral (earth pole) of the power supply.



Before operating the unit, ensure the conductor (green wire) is connected to the ground (earth) conductor of the power outlet. Do not use a two-conductor extension cord or a three-prong/two-prong adapter. This will defeat the protective feature of the third conductor in the power cord.



Maintenance and calibration procedures sometimes call for operation of the unit with power applied and protective covers removed. Read the procedures and heed warnings to avoid “live” circuit points.

Before operating this instrument:

1. Ensure the proper fuse is in place for the power source to operate.
2. Ensure all other devices connected to or in proximity to this instrument are properly grounded or connected to the protective third-wire earth ground.

If the instrument:

- fails to operate satisfactorily
- shows visible damage
- has been stored under unfavorable conditions
- has sustained stress

Do not operate until, performance is checked by qualified personnel.

This page was left intentionally blank.

Table of Contents

Chapter 1

SPECIFICATIONS	1-1
Introduction – 1260-162A/B	1-1
Power Dissipation – 1260-162A/B	1-3
Ordering Information.....	1-4

Chapter 2

INSTALLATION INSTRUCTIONS	2-1
Unpacking and Inspection	2-1
Reshipment Instructions	2-2
Installation:.....	2-2
Module Configuration.....	2-2
Front Panel Connectors 1260-162A.....	2-2
Front Panel Connectors 1260-162B.....	2-4
Mating Connectors.....	2-6

Chapter 3

MODULE OPERATION.....	3-1
Reply to the MOD:LIST? Command	3-1
Operating in Register-Based Mode.....	3-2
1260-162 Example Code.....	3-6

Chapter 4

DRAWINGS	4-1
----------------	-----

Chapter 5

PARTS LIST.....	5-1
-----------------	-----

Chapter 6

PRODUCT SUPPORT.....	6-1
----------------------	-----

Product Support 6-1
Reshipment Instructions 6-1
Support Offices 6-2

List of Figures

Figure 1-1, 1260-162B	1-1
Figure 2-1, 1260-162A SMA Connector Designations	2-2
Figure 2-2, 1260-162A Relay Diagram	2-3
Figure 2-3, 1260-162A Block Diagram.....	2-3
Figure 2-4, 1260-162A SMA Connector Designations	2-4
Figure 2-5, 1260-162B Relay Diagram	2-5
Figure 2-6, 1260-162B Block Diagram	2-5

List of Tables

Table 3-1, Register Offset Addresses of the 1260-162 Module	3-3
Table 3-2, ID Register Functionality of the 1260-162.....	3-3
Table 3-3, Port A Register Functionality of the 1260-162 Module.....	3-4
Table 3-4, EPROM Descriptor Functionality of the 1260-162 Module.....	3-4

This page was left intentionally blank.

Chapter 1

SPECIFICATIONS

Introduction – 1260-162A/B

The 1260-162A and 1260-162B are RF plug-in switch modules developed for a variety of Racal Instrument platforms such as the 1260-100 Adapt-a-Switch Carrier and the 1256 Switching System. These switches are software-configurable single (–162A) and dual DPDT (–162B) RF Transfer Switches for DC to 18GHz.

The 1260-162 modules include the following features:

- Standard Adapt-a-Switch™ and 1256 Switching System plug-in design, providing for ease of replacement.
- Data-Driven embedded descriptor, allowing immediate use with any platform compatible with the Adapt-a-Switch standard, regardless of firmware level.

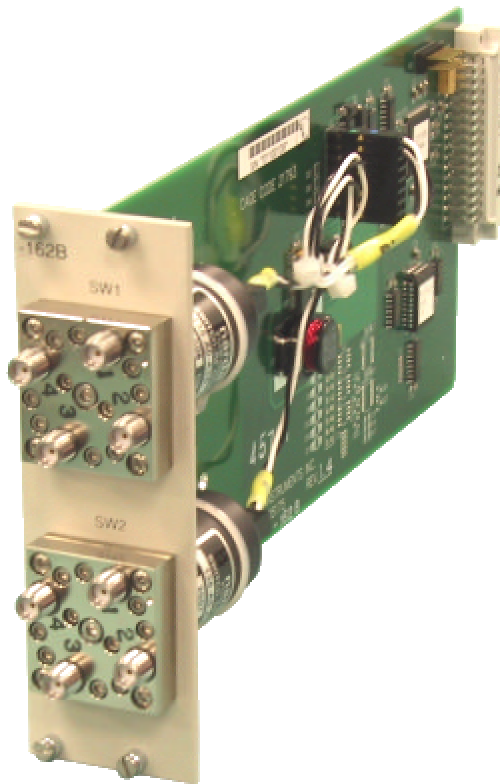

Figure 1-1, 1260-162B

Specifications – 1260-162A/B

Input / Output Specifications					
Frequency Range (GHz)	DC-3	3-8	8-12.4	12.4-18	
VSWR (Max dB)	1.2:1	1.3:1	1.4:1	1.5:1	
Insertion loss (Max dB)	0.2	0.3	0.4	0.5	
Isolation (Max dB)	80	70	60	60	
Impedance	50 Ω nominal				
RF Input Power					
Frequency Range (GHz)	DC-0.1	0.1-1	1-10	10-18	
Max Input Power (Watts)	490	180	60	50	
Relay Operate Time	15m sec typical				
Switch Contact Lifetime	1 Million cycles per position				
Available I/O Channels	Single 2x2 RF Transfer Switch				
Shock	30g, 11 ms, ½ sine wave				
Vibration	0.013 in. P-P, 5-55 Hz				
Bench Handling	4 in., 45°				
Cooling	See 1260-100 cooling data				
Temperature					
Operating	-20°C to +60°C				
Non-operating	-40°C to +75°C				
Relative Humidity	95 +/-5% RH non condensing; 75+/-5 %RH above 30°C; 45+/-5 %RH above 40°C				
Altitude					
Operating	10,000 feet				
Non-operating	15,000 feet				
Power Requirements	1260-162A	1.77 A			
+5 VDC Amps Maximum	1260-162B	3.53 A			

Weight	1260-162A	5.4 oz, 150 gm
	1260-162B	7.0 oz, 200 gm
Mean Time Between Failures (MTBF)	860,000 hrs	
		Calculated per MIL-HBK-217, ground-benign, 30°C, as design goal (RF relay MTBF 1,000,000 operations per switch at rated load)
Mean Time to Repair (MTTR)	< 5 minutes	

Power Dissipation – 1260-162A/B

The cooling of the Adapt-a-Switch carrier is dependent upon the chassis into which it is installed. The carrier can nominally dissipate approximately 100W. Even with all channels driven to maximum outputs, up to two 1260-162A plug-ins may be used together in a 1260-100 without exceeding the maximum allowable power dissipation of the carrier.

If the 1260-162A will be used in conjunction with other cards, the dissipation should be computed and summed with the total worst-case dissipation of the remaining modules.

For example, a 1260-162A module would dissipate the following energy:

Quiescent power dissipation = 0.75W maximum

With one relay energized = 8.85 W maximum

For example, a 1260-162B module would dissipate the following energy:

Quiescent power dissipation = 0.75W maximum

With one coil energized = 8.85 W maximum

With two coils energized = 17.65 W maximum

This is acceptable power dissipation for an individual plug-in module. If one additional module is likewise loaded, then the overall carrier dissipation is approximately 17.7W for the –162A and 35.3W for the –162B, both of which are well within the cooling available in most commercial VXIbus chassis.

Ordering Information

Listed below are part numbers for both the 1260-162 switch module and available mating connector accessories. Each 1260-162 uses a single mating connector.

ITEM	DESCRIPTION	PART #
1260-162A RF Mux Module	Switch Module, 1 2x2 DC-18 GHz Consists of: P/N 407782-001 PCB Assy P/N 980824-162 Manual	407767-001
1260-162B RF Mux Module	Switch Module, 2 2x2 DC-18 GHz Consists of: P/N 407782-002 PCB Assy P/N 980824-162 Manual	407767-002
Additional Manual		980824-162

INSTALLATION INSTRUCTIONS

Unpacking and Inspection



1. Before unpacking the switching module, check the exterior of the shipping carton for any signs of damage. All irregularities should be noted on the shipping bill and reported.

CAUTION

ESD sensitive devices. Open the instrument at an ESD safe work station.

WARNING

Connections to the 1260-162 module should be made with all RF power removed.

2. Remove the instrument from its carton, preserving the factory packaging as much as possible.
3. Inspect the switching module for any defects or damage. Immediately notify the carrier if any damage is apparent.
4. Have a qualified person check the instrument for safety before use.

Reshipment Instructions

1. Use the original packing material when returning the switching module to Racal Instruments for servicing. The original shipping carton and the instrument's plastic foam will provide the necessary support for safe reshipment.
2. If the original packing material is unavailable, wrap the switching module in an ESD Shielding bag and use plastic spray foam to surround and protect the instrument.
3. Reship in either the original or a new shipping carton.

Installation:

For instructions on installing the 1260-162 into a switching platform, refer to the user manual for that platform, in the "Getting Started" chapter under the "Inserting and Removing Plug-ins" section. Manuals are available at the Racal Instruments' web site: <http://www.racalstruments.com>.

Module Configuration

The 1260-162 modules are software-selectable multiplexer plug-ins for Racal Instruments switching platforms such as Adapt-a-Switch and 1256 System. The 1260-162A is a single DPDT RF Transfer Switch, and the 1260-162B is a dual DPDT RF Transfer Switch.

Front Panel Connectors 1260-162A

The 1260-162A has one front panel RF relay, labeled SW1, with 4 SMA connectors. See Figure 2-1 for SMA connector designations. See Figure 2-2 for the relay diagram, and Figure 2-3 for a block diagram of the 1260-162A.

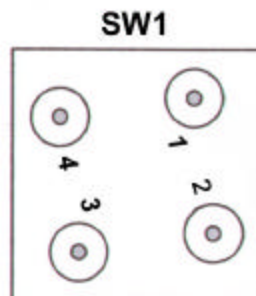

Figure 2-1, 1260-162A SMA Connector Designations

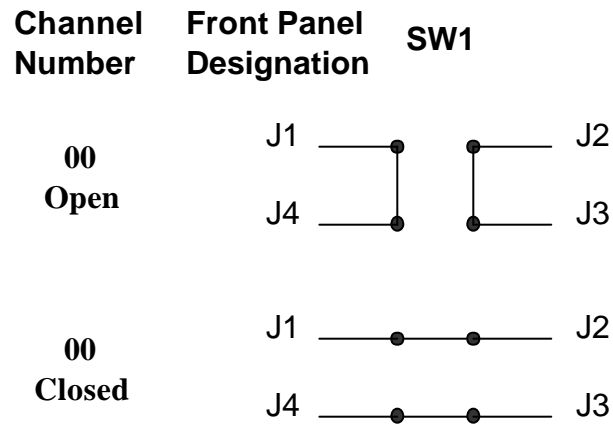

Figure 2-2, 1260-162A Relay Diagram

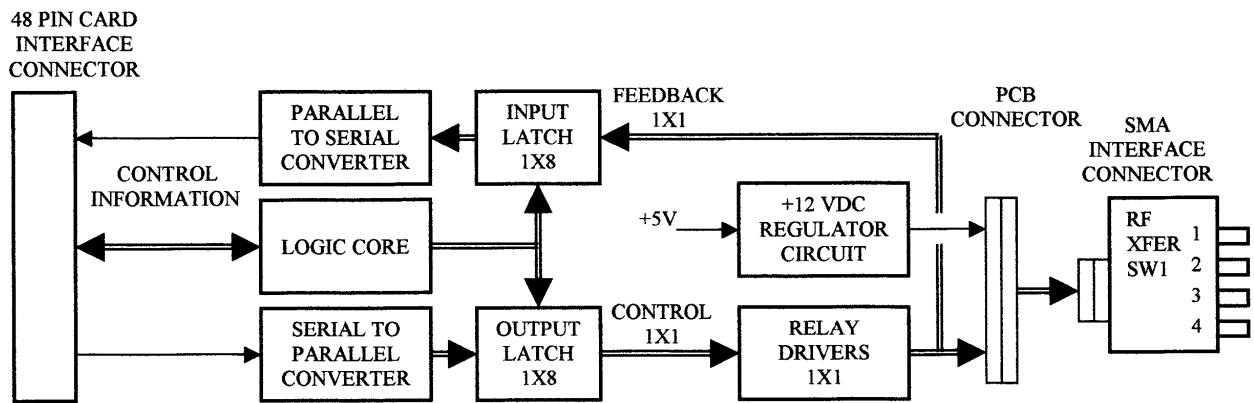

Figure 2-3, 1260-162A Block Diagram

**Front Panel
Connectors 1260-
162B**

The 1260-162B has two front panel RF relays, labeled SW1 and SW2, with 4 SMA connectors each. See Figure 2-4 for SMA connector designations. See Figure 2-5 for the relay diagram and Figure 2-6 for a block diagram of the 1260-162B.

See page 2-6 for torque requirements.

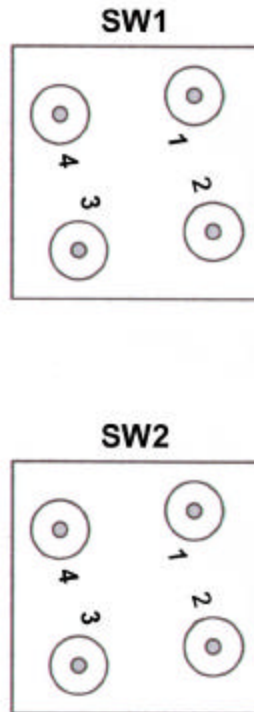

Figure 2-4, 1260-162A SMA Connector Designations

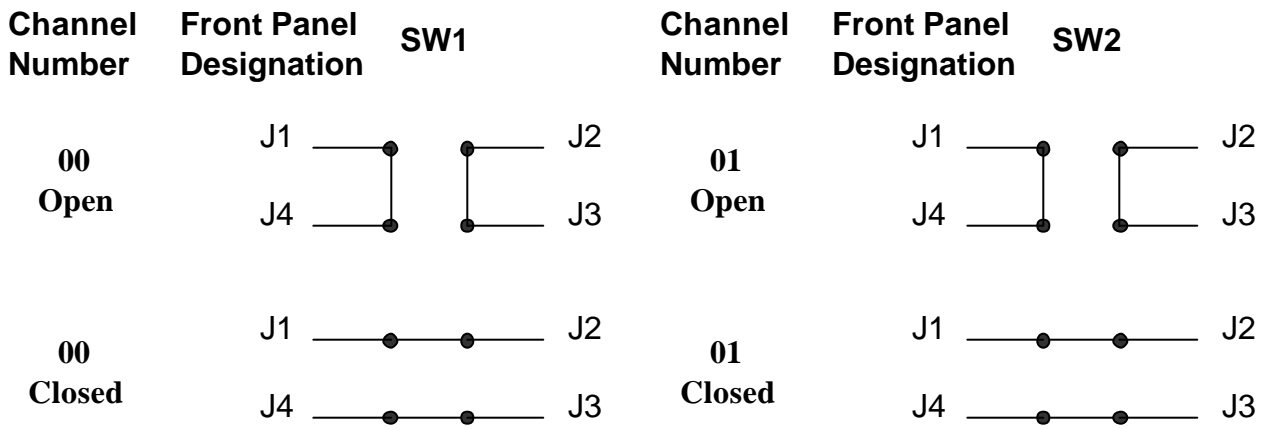

Figure 2-5, 1260-162B Relay Diagram

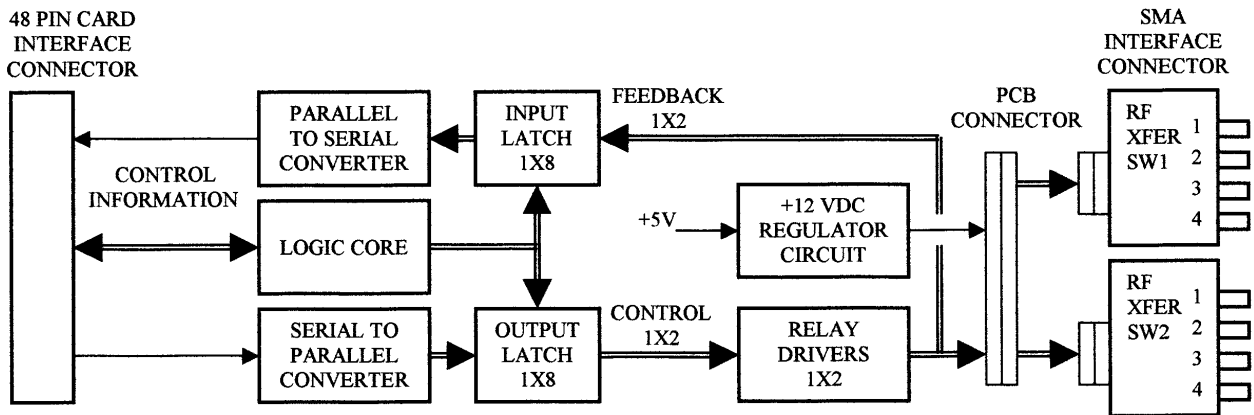

Figure 2-6, 1260-162B Block Diagram

Mating Connectors



Mating connectors are SMA type. Use connectors that are suitable for the type of connecting coax and frequency range to be used. **Maximum connector engagement should not exceed 9 in. lbs. torque.** It is highly recommended that a torque wrench (Ma-Com P/N 2098-5065-54 or equivalent) be used to torque the SMA connectors. A ¼ inch drive Deep Slotted Socket, P/N 456890, is available for installation and removal of connectors.

MODULE OPERATION

Reply to the MOD:LIST? Command

The platform containing the 1260-162 returns a reply to the MOD:LIST? command. This reply is unique for each different 1260 series switch module. The syntax for the reply is:

<module address> : <module-specific identification string>

The value of <module-specific identification string> for the 1260-162 depends on the version (1260-162A or 1260-162B). For the single transfer switch (1260-162A), the string value is:

```
1260-162A SINGLE RF TRANSFER SWITCHING MODULE
```

For the two transfer switches (1260-162B), the string value is:

```
1260-162B DUAL RF TRANSFER SWITCHING MODULE
```

Thus, for a 1260-162A whose module address is 2, the reply to this query would be:

```
2 : 1260-162A SINGLE RF TRANSFER SWITCHING MODULE
```

Operating in Register-Based Mode

The 1260-162 offers register-based mode when installed in VXI platforms that support it. In register-based mode, the 1260-162 is operated by directly writing and reading to/from ports controlling eight relays each. To access the various registers the following details must be assembled to generate an absolute address that can be wrote or read from:

The port and control registers are located in the VXIbus A24 Address Space. The A24 address for a port or control register depends on:

1. The A24 Address Offset assigned to the 1260-01T module by the Resource Manager program. The Resource Manager program is provided by the VXIbus slot-0 controller vendor. The A24 Address Offset is placed into the "Offset Register" of the 1260-01T by the Resource Manager.
2. The <module address> of the 1260-162 module. This is a value in the range from 1 and 12 inclusive.
3. The 1260-162 port or control register to be written to or read from. Each register on the 1260-162 has a unique offset from the base address.

The base A24 address for the 1260-162 module may be calculated by:

$$(A24 \text{ Offset of the } 1260-01T) + (1024 \times \text{Module Address of } 1260-162).$$

The A24 address offset is usually expressed in hexadecimal. A typical value of 204000_{16} is used in the examples that follow.

A 1260-162 with a module address of 7 would have the base A24 address computed as follows:

$$\text{Base A24 Address of } 1260-162 = 204000_{16} + (400_{16} \times 7_{10}) = 205C00_{16}$$

The port and control registers for Adapt-a-Switch plug-ins and conventional 1260-Series modules are always on odd-numbered A24 addresses. For port registers, the 1260-162 reads and writes to the same location. For control registers, the 1260-162 writes to one location, but reads back from another. **Table 3-1** provides offsets relative to the base address of the module for all port and control registers of the 1260-162. To obtain the absolute address where data is to be written or read from, the base address is added to the offset:

(Base A24 1260-162 Address) + offset = absolute address

So, for our example base A24 address computed earlier, the following absolute addresses would apply for the operations indicated:

205C01 Port A read or written at this location

205E01 ID register read at this location

Before explaining the particulars of reading and writing to port and control registers, it is necessary to understand how the registers interact with the 1260-162 relays. **Table 3-1, through 3-4** provide a detailed explanation of each register and how it interacts with the 1260-162 module.

Table 3-1, Register Offset Addresses of the 1260-162 Module

Register Name	Register Offsets to Add to Base Module Address	
	Write Location (hexadecimal)	Read Location (hexadecimal)
Port A	0x01	0x01
ID	Read Only	0x201
EPROM Descriptor	Read Only	0x203

Table 3-2, ID Register Functionality of the 1260-162

Register Table		ID Register
Module Version	Bit	Functionality Description
All	0	Always Reads 0x00 (Read Only)
	1	
	2	
	3	
	4	
	5	
	6	
	7	

Table 3-3, Port A Register Functionality of the 1260-162 Module

Register Table		Port A	
Module Version	Bit	Functionality Description	
All -162B	0	Relay SW1	(0: switch open 1: switch closed)
	1	Relay SW2	(0: switch open 1: switch closed)
	2	(not used)	
	3	(not used)	
	4	(not used)	
	5	(not used)	
	6	(not used)	
	7	(not used)	

Table 3-4, EPROM Descriptor Functionality of the 1260-162 Module

Register Table		EPROM Descriptor Register	
Module Version	Bit	Functionality Description	
All	0	Each time this register is read, it advances a memory pointer to the next memory location in the on-board EPROM. To reset this pointer to the beginning, read the ID register. This resets the memory pointer. The descriptor register contains a long string of data, typically used by the Adapt-a-Switch carrier for configuration purposes. Additionally, this data contains the card identification string for the specific type of card (i.e. 1260-162A or 1260-162B). These identification strings are located at EPROM memory locations 0x23 through 0x34.	
	1		
	2		
	3		
	4		
	5		
	6		
	7		

Writing to a port location is a straightforward process. Setting a bit high in a port register causes the corresponding relay channel to close.

It is especially important to realize that a single write operation controls eight separate control lines or output devices simultaneously. Therefore if only a single bit change is desired, the following process must be observed.

1. Read the register, inverting the bit pattern.
2. Mask the appropriate bit with an 'AND' operation and a byte mask with all undesired bits set to a '1' and the desired bit set to a '0' or '1' depending on whether the bit is to be set or cleared in the desired register.
3. Write the masked data back into the register.

As simple as this may seem, a number of products reported as faulty and sent back for repair are typically the result of inappropriate register accesses.

Because of the 1260-162 relay driver architecture, registers A and B will read back inverted from what was written to them.

The VISA I/O library may be used to control the module. The VISA function `viOut8()` is used to write a single 8-bit byte to a control register, while `viIn8()` is used to read a single 8-bit byte from the control register. The following code example shows the use of `viOut8()` to update the 1260-162 module.

1260-162 Example Code

```
#include <visa.h>

/* This example shows a 1260-01T at logical address 16 and a VXI/MXI */
/* interface */
#define RI1260_01_DESC    "VXI::16"

/* For a GPIB-VXI interface, and a logical address of 77 */
/* the descriptor would be: "GPIB-VXI::77" */

/* this example shows a 1260-162 with module address 7, port 1,
and write data of 0xAA */
#define MOD_ADDR_162 7
#define PORT_NUMBER 1
#define DATA_ITEM    0xAA

void example_operate_1260_162(void)
{
    ViUInt8 creg_val;
    ViBusAddress portA_addr, offset;
    ViSession hdl1260;    /* VISA handle to the 1260-01T */
    ViSession hdlRM;      /* VISA handle to the resource manager
*/
    ViStatus error;      /* VISA error code */

    /* open the resource manager */
    /* this must be done once in application program */
    error = viOpenDefaultRM (&hdlRM);

    if (error < 0) {
        /* error handling code goes here */
    }

    /* get a handle for the 1260-01T */
    error = viOpen (hdlRM, RI1260_01_DESC, VI_NULL,VI_NULL, &hdl1260);
    if (error < 0) {
        /* error handling code goes here */
    }
}
```



```
/* form the offset for control register 0 */
/* note that the base A24 Address for the 1260-01T */
/* is already accounted for by VISA calls viIn8() and */
/* viOut8() */

/* module address shifted 10 places = module address x 1024 */
portA_addr = (MOD_ADDR_162 << 10) + 1;
offset = portA_addr + (PORT_NUMBER << 1);

error = viOut8 (vi, VI_A24_SPACE, offset, DATA_ITEM);

if (error < 0)

    return( error );

/* close the VISA session */
error = viClose( hdl1260 );
if (error < 0) {
    /* error handling code goes here */
}
}
```

This page was left intentionally blank.

Chapter 4

DRAWINGS

405175-162A/B, PCB Assembly, 1260-162A/B.....	4-3
435175, Schematic, 1260-160, -162, -164	4-4

This page was left intentionally blank.

1	2	3	4
DWG. NO. 435175		SH. 1	REV. B
REVISIONS			
REV	DESCRIPTION	DATE	APPROVED
A	DOCUMENT CONTROL RELEASE	01/02/27	DB
B	REVISED PER ED MOD 179	01/02/23	J.ROBINSON
	REVISED PER ED NO.		
	REVISED PER ED NO.		

NOTES:

1. CAPACITOR VALUES ARE IN MICROFARADS, UNLESS OTHERWISE SPECIFIED.
2. RESISTOR VALUES ARE IN OHMS, UNLESS OTHERWISE SPECIFIED.
3. ALL DIGITAL PORTS SIGNALS BETWEEN SHEETS ARE INDICATED USING THE FOLLOWING SYNTAX:
 <ACTIVE LOGIC LEVEL>-<SIGNAL NAME> WHERE ACTIVE LOGIC LEVELS INDICATED AS:
 H- SIGNAL IS ACTIVE HIGH OR CLOCKS ON A LOW TO HIGH TRANSITION
 L- SIGNAL IS ACTIVE LOW OR CLOCKS ON A HIGH TO LOW TRANSITION
 NONE- SIGNAL ACTIVITY IS DETERMINED BY SOFTWARE OR USER CONFIGURATION
4. RESISTOR NETWORK VALUES ARE IN OHMS, +/-2% UNLESS OTHERWISE SPECIFIED.
5. NOT USED.
6. INDUCTOR VALUES ARE IN MICROHENRYS, UNLESS OTHERWISE SPECIFIED.

▲ SEE SHEET 2 FOR COMPONENT USAGE

COMPONENT USAGE 435175_1	READBACK SERIALIZER 435175_2
CONNECTION INTERFACE 435175_3	FRSA LOGIC CORE 435175_7
GENERAL PURPOSE I/O WRITE-PORTS A-B 435175_4	+5 TO +12 BOOST CONVERTER 435175_8
GENERAL PURPOSE I/O READBACK-PORTS A-B 435175_5	BYPASS CAPACITORS 435175_9

REFERENCE DESIGNATOR(S)	IC-POWER CONNECTIONS DEVICE TYPE	+5 VFN NO.	GND PIN NO.
U1-U4	74AHCT373	20	10
U6	74HCT164	14	7
U5	74HCT186	16	8
U7-U8	74HCT393	14	7
U9	27C256	32	16
U10	231055-008 (EP-M76643T)	31,18,34,35,66,62,61	11,26,39,43,59,74,86,95

CAD CURRENT REV/LTR FOR SHEET 51 THRU 9 DRAWN WITH PROTEL 99SE

PROPRIETARY NOTICE

THIS DOCUMENT AND THE TECHNICAL DATA HEREON DISCLOSED ARE PROPRIETARY INFORMATION OF RACAL INSTRUMENTS INC. AND WILL BE KEPT CONFIDENTIAL AND NOT REPRODUCED OR IN PART OR USED TO SOLICIT QUOTATION FROM A COMPETITIVE SOURCE FOR INVENTION OR RESEARCH OR BE REPRODUCED OR TRANSMITTED IN ANY FORM AND BY ANY MEANS, ELECTRONIC OR MECHANICAL, INCLUDING PHOTOCOPYING, RECORDING, AND INFORMATION RETRIEVAL SYSTEMS, WITHOUT THE WRITTEN PERMISSION OF RACAL INSTRUMENTS INC. THIS NOTICE APPLIES TO ALL FORMS OF REPRODUCTION AND SPECIFIC PROTECTION OF PRODUCTS FROM RACAL INSTRUMENTS INC.

TITLE		SCALE	SHEET 1	OF 9
RACAL Instruments, Inc. 4 Goodyear St., Irvine, CA. 92618		NONE	30-Oct-2001	4
SIZE	CAGE CODE	DWG NO.	REV.	
B	21793	435175	B	

1	2	3	4																																																																																																																																																																																																																																																																																																																																																																																																																																																																																																																																																																																																																																																																																																																																																																																																																																																																																																																																																																																																																																																																																																																																																																																																																																																																																																																																																																																																																																																																																																																																																																																																																																																																																																																																																																																																																																																																																																																																																																																																																																																																			
D	C	B	A																																																																																																																																																																																																																																																																																																																																																																																																																																																																																																																																																																																																																																																																																																																																																																																																																																																																																																																																																																																																																																																																																																																																																																																																																																																																																																																																																																																																																																																																																																																																																																																																																																																																																																																																																																																																																																																																																																																																																																																																																																																																			
<p>FOR REFERENCE ONLY</p> <p>COMPONENT USAGE VS MODEL NUMBER (X MEANS USED)</p> <table border="1" style="width: 100%; border-collapse: collapse; font-size: 8px;"> <thead> <tr> <th>MODEL #</th> <th>1260-160A</th> <th>1260-160B</th> <th>1260-160C</th> <th>1260-160D</th> <th>1260-160E</th> <th>1260-160F</th> <th>1260-160G</th> <th>1260-160H</th> <th>1260-160I</th> <th>1260-160J</th> <th>1260-160K</th> <th>1260-160L</th> <th>1260-160M</th> <th>1260-160N</th> <th>1260-160O</th> <th>1260-160P</th> <th>1260-160Q</th> <th>1260-160R</th> <th>1260-160S</th> <th>1260-160T</th> <th>1260-160U</th> <th>1260-160V</th> <th>1260-160W</th> <th>1260-160X</th> <th>1260-160Y</th> <th>1260-160Z</th> </tr> </thead> <tbody> <tr><td>R31</td><td>X</td><td></td><td></td><td></td><td></td><td></td><td></td><td></td><td></td><td></td><td></td><td></td><td></td><td></td><td></td><td></td><td></td><td></td><td></td><td></td><td></td><td></td><td></td><td></td><td></td><td></td><td></td></tr> <tr><td>R32</td><td>X</td><td></td><td></td><td></td><td></td><td></td><td></td><td></td><td></td><td></td><td></td><td></td><td></td><td></td><td></td><td></td><td></td><td></td><td></td><td></td><td></td><td></td><td></td><td></td><td></td><td></td><td></td></tr> <tr><td>R33</td><td>X</td><td></td><td></td><td></td><td></td><td></td><td></td><td></td><td></td><td></td><td></td><td></td><td></td><td></td><td></td><td></td><td></td><td></td><td></td><td></td><td></td><td></td><td></td><td></td><td></td><td></td><td></td></tr> <tr><td>R34</td><td>X</td><td></td><td></td><td></td><td></td><td></td><td></td><td></td><td></td><td></td><td></td><td></td><td></td><td></td><td></td><td></td><td></td><td></td><td></td><td></td><td></td><td></td><td></td><td></td><td></td><td></td><td></td></tr> <tr><td>R35</td><td>X</td><td></td><td></td><td></td><td></td><td></td><td></td><td></td><td></td><td></td><td></td><td></td><td></td><td></td><td></td><td></td><td></td><td></td><td></td><td></td><td></td><td></td><td></td><td></td><td></td><td></td><td></td></tr> <tr><td>R36</td><td>X</td><td></td><td></td><td></td><td></td><td></td><td></td><td></td><td></td><td></td><td></td><td></td><td></td><td></td><td></td><td></td><td></td><td></td><td></td><td></td><td></td><td></td><td></td><td></td><td></td><td></td><td></td></tr> <tr><td>R37</td><td>X</td><td></td><td></td><td></td><td></td><td></td><td></td><td></td><td></td><td></td><td></td><td></td><td></td><td></td><td></td><td></td><td></td><td></td><td></td><td></td><td></td><td></td><td></td><td></td><td></td><td></td><td></td></tr> <tr><td>R38</td><td>X</td><td></td><td></td><td></td><td></td><td></td><td></td><td></td><td></td><td></td><td></td><td></td><td></td><td></td><td></td><td></td><td></td><td></td><td></td><td></td><td></td><td></td><td></td><td></td><td></td><td></td><td></td></tr> <tr><td>R39</td><td>X</td><td></td><td></td><td></td><td></td><td></td><td></td><td></td><td></td><td></td><td></td><td></td><td></td><td></td><td></td><td></td><td></td><td></td><td></td><td></td><td></td><td></td><td></td><td></td><td></td><td></td><td></td></tr> <tr><td>R40</td><td>X</td><td></td><td></td><td></td><td></td><td></td><td></td><td></td><td></td><td></td><td></td><td></td><td></td><td></td><td></td><td></td><td></td><td></td><td></td><td></td><td></td><td></td><td></td><td></td><td></td><td></td><td></td></tr> <tr><td>R41</td><td>X</td><td></td><td></td><td></td><td></td><td></td><td></td><td></td><td></td><td></td><td></td><td></td><td></td><td></td><td></td><td></td><td></td><td></td><td></td><td></td><td></td><td></td><td></td><td></td><td></td><td></td><td></td></tr> <tr><td>R42</td><td>X</td><td></td><td></td><td></td><td></td><td></td><td></td><td></td><td></td><td></td><td></td><td></td><td></td><td></td><td></td><td></td><td></td><td></td><td></td><td></td><td></td><td></td><td></td><td></td><td></td><td></td><td></td></tr> <tr><td>R43</td><td>X</td><td></td><td></td><td></td><td></td><td></td><td></td><td></td><td></td><td></td><td></td><td></td><td></td><td></td><td></td><td></td><td></td><td></td><td></td><td></td><td></td><td></td><td></td><td></td><td></td><td></td><td></td></tr> <tr><td>R44</td><td>X</td><td></td><td></td><td></td><td></td><td></td><td></td><td></td><td></td><td></td><td></td><td></td><td></td><td></td><td></td><td></td><td></td><td></td><td></td><td></td><td></td><td></td><td></td><td></td><td></td><td></td><td></td></tr> <tr><td>R45</td><td>X</td><td></td><td></td><td></td><td></td><td></td><td></td><td></td><td></td><td></td><td></td><td></td><td></td><td></td><td></td><td></td><td></td><td></td><td></td><td></td><td></td><td></td><td></td><td></td><td></td><td></td><td></td></tr> <tr><td>R46</td><td>X</td><td></td><td></td><td></td><td></td><td></td><td></td><td></td><td></td><td></td><td></td><td></td><td></td><td></td><td></td><td></td><td></td><td></td><td></td><td></td><td></td><td></td><td></td><td></td><td></td><td></td><td></td></tr> <tr><td>R47</td><td>X</td><td></td><td></td><td></td><td></td><td></td><td></td><td></td><td></td><td></td><td></td><td></td><td></td><td></td><td></td><td></td><td></td><td></td><td></td><td></td><td></td><td></td><td></td><td></td><td></td><td></td><td></td></tr> <tr><td>R48</td><td>X</td><td></td><td></td><td></td><td></td><td></td><td></td><td></td><td></td><td></td><td></td><td></td><td></td><td></td><td></td><td></td><td></td><td></td><td></td><td></td><td></td><td></td><td></td><td></td><td></td><td></td><td></td></tr> <tr><td>R49</td><td>X</td><td></td><td></td><td></td><td></td><td></td><td></td><td></td><td></td><td></td><td></td><td></td><td></td><td></td><td></td><td></td><td></td><td></td><td></td><td></td><td></td><td></td><td></td><td></td><td></td><td></td><td></td></tr> <tr><td>R50</td><td>X</td><td></td><td></td><td></td><td></td><td></td><td></td><td></td><td></td><td></td><td></td><td></td><td></td><td></td><td></td><td></td><td></td><td></td><td></td><td></td><td></td><td></td><td></td><td></td><td></td><td></td><td></td></tr> <tr><td>R51</td><td>X</td><td></td><td></td><td></td><td></td><td></td><td></td><td></td><td></td><td></td><td></td><td></td><td></td><td></td><td></td><td></td><td></td><td></td><td></td><td></td><td></td><td></td><td></td><td></td><td></td><td></td><td></td></tr> <tr><td>R52</td><td>X</td><td></td><td></td><td></td><td></td><td></td><td></td><td></td><td></td><td></td><td></td><td></td><td></td><td></td><td></td><td></td><td></td><td></td><td></td><td></td><td></td><td></td><td></td><td></td><td></td><td></td><td></td></tr> <tr><td>R53</td><td>X</td><td></td><td></td><td></td><td></td><td></td><td></td><td></td><td></td><td></td><td></td><td></td><td></td><td></td><td></td><td></td><td></td><td></td><td></td><td></td><td></td><td></td><td></td><td></td><td></td><td></td><td></td></tr> <tr><td>R54</td><td>X</td><td></td><td></td><td></td><td></td><td></td><td></td><td></td><td></td><td></td><td></td><td></td><td></td><td></td><td></td><td></td><td></td><td></td><td></td><td></td><td></td><td></td><td></td><td></td><td></td><td></td><td></td></tr> <tr><td>R55</td><td>X</td><td></td><td></td><td></td><td></td><td></td><td></td><td></td><td></td><td></td><td></td><td></td><td></td><td></td><td></td><td></td><td></td><td></td><td></td><td></td><td></td><td></td><td></td><td></td><td></td><td></td><td></td></tr> <tr><td>R56</td><td>X</td><td></td><td></td><td></td><td></td><td></td><td></td><td></td><td></td><td></td><td></td><td></td><td></td><td></td><td></td><td></td><td></td><td></td><td></td><td></td><td></td><td></td><td></td><td></td><td></td><td></td><td></td></tr> <tr><td>R57</td><td>X</td><td></td><td></td><td></td><td></td><td></td><td></td><td></td><td></td><td></td><td></td><td></td><td></td><td></td><td></td><td></td><td></td><td></td><td></td><td></td><td></td><td></td><td></td><td></td><td></td><td></td><td></td></tr> <tr><td>R58</td><td>X</td><td></td><td></td><td></td><td></td><td></td><td></td><td></td><td></td><td></td><td></td><td></td><td></td><td></td><td></td><td></td><td></td><td></td><td></td><td></td><td></td><td></td><td></td><td></td><td></td><td></td><td></td></tr> <tr><td>R59</td><td>X</td><td></td><td></td><td></td><td></td><td></td><td></td><td></td><td></td><td></td><td></td><td></td><td></td><td></td><td></td><td></td><td></td><td></td><td></td><td></td><td></td><td></td><td></td><td></td><td></td><td></td><td></td></tr> <tr><td>R60</td><td>X</td><td></td><td></td><td></td><td></td><td></td><td></td><td></td><td></td><td></td><td></td><td></td><td></td><td></td><td></td><td></td><td></td><td></td><td></td><td></td><td></td><td></td><td></td><td></td><td></td><td></td><td></td></tr> <tr><td>R61</td><td>X</td><td></td><td></td><td></td><td></td><td></td><td></td><td></td><td></td><td></td><td></td><td></td><td></td><td></td><td></td><td></td><td></td><td></td><td></td><td></td><td></td><td></td><td></td><td></td><td></td><td></td><td></td></tr> <tr><td>R62</td><td>X</td><td></td><td></td><td></td><td></td><td></td><td></td><td></td><td></td><td></td><td></td><td></td><td></td><td></td><td></td><td></td><td></td><td></td><td></td><td></td><td></td><td></td><td></td><td></td><td></td><td></td><td></td></tr> <tr><td>R63</td><td>X</td><td></td><td></td><td></td><td></td><td></td><td></td><td></td><td></td><td></td><td></td><td></td><td></td><td></td><td></td><td></td><td></td><td></td><td></td><td></td><td></td><td></td><td></td><td></td><td></td><td></td><td></td></tr> <tr><td>R64</td><td>X</td><td></td><td></td><td></td><td></td><td></td><td></td><td></td><td></td><td></td><td></td><td></td><td></td><td></td><td></td><td></td><td></td><td></td><td></td><td></td><td></td><td></td><td></td><td></td><td></td><td></td><td></td></tr> <tr><td>R65</td><td>X</td><td></td><td></td><td></td><td></td><td></td><td></td><td></td><td></td><td></td><td></td><td></td><td></td><td></td><td></td><td></td><td></td><td></td><td></td><td></td><td></td><td></td><td></td><td></td><td></td><td></td><td></td></tr> <tr><td>R66</td><td>X</td><td></td><td></td><td></td><td></td><td></td><td></td><td></td><td></td><td></td><td></td><td></td><td></td><td></td><td></td><td></td><td></td><td></td><td></td><td></td><td></td><td></td><td></td><td></td><td></td><td></td><td></td></tr> <tr><td>R67</td><td>X</td><td></td><td></td><td></td><td></td><td></td><td></td><td></td><td></td><td></td><td></td><td></td><td></td><td></td><td></td><td></td><td></td><td></td><td></td><td></td><td></td><td></td><td></td><td></td><td></td><td></td><td></td></tr> <tr><td>R68</td><td>X</td><td></td><td></td><td></td><td></td><td></td><td></td><td></td><td></td><td></td><td></td><td></td><td></td><td></td><td></td><td></td><td></td><td></td><td></td><td></td><td></td><td></td><td></td><td></td><td></td><td></td><td></td></tr> <tr><td>R69</td><td>X</td><td></td><td></td><td></td><td></td><td></td><td></td><td></td><td></td><td></td><td></td><td></td><td></td><td></td><td></td><td></td><td></td><td></td><td></td><td></td><td></td><td></td><td></td><td></td><td></td><td></td><td></td></tr> <tr><td>R70</td><td>X</td><td></td><td></td><td></td><td></td><td></td><td></td><td></td><td></td><td></td><td></td><td></td><td></td><td></td><td></td><td></td><td></td><td></td><td></td><td></td><td></td><td></td><td></td><td></td><td></td><td></td><td></td></tr> <tr><td>R71</td><td>X</td><td></td><td></td><td></td><td></td><td></td><td></td><td></td><td></td><td></td><td></td><td></td><td></td><td></td><td></td><td></td><td></td><td></td><td></td><td></td><td></td><td></td><td></td><td></td><td></td><td></td><td></td></tr> <tr><td>R72</td><td>X</td><td></td><td></td><td></td><td></td><td></td><td></td><td></td><td></td><td></td><td></td><td></td><td></td><td></td><td></td><td></td><td></td><td></td><td></td><td></td><td></td><td></td><td></td><td></td><td></td><td></td><td></td></tr> <tr><td>R73</td><td>X</td><td></td><td></td><td></td><td></td><td></td><td></td><td></td><td></td><td></td><td></td><td></td><td></td><td></td><td></td><td></td><td></td><td></td><td></td><td></td><td></td><td></td><td></td><td></td><td></td><td></td><td></td></tr> <tr><td>R74</td><td>X</td><td></td><td></td><td></td><td></td><td></td><td></td><td></td><td></td><td></td><td></td><td></td><td></td><td></td><td></td><td></td><td></td><td></td><td></td><td></td><td></td><td></td><td></td><td></td><td></td><td></td><td></td></tr> <tr><td>R75</td><td>X</td><td></td><td></td><td></td><td></td><td></td><td></td><td></td><td></td><td></td><td></td><td></td><td></td><td></td><td></td><td></td><td></td><td></td><td></td><td></td><td></td><td></td><td></td><td></td><td></td><td></td><td></td></tr> <tr><td>R76</td><td>X</td><td></td><td></td><td></td><td></td><td></td><td></td><td></td><td></td><td></td><td></td><td></td><td></td><td></td><td></td><td></td><td></td><td></td><td></td><td></td><td></td><td></td><td></td><td></td><td></td><td></td><td></td></tr> <tr><td>R77</td><td>X</td><td></td><td></td><td></td><td></td><td></td><td></td><td></td><td></td><td></td><td></td><td></td><td></td><td></td><td></td><td></td><td></td><td></td><td></td><td></td><td></td><td></td><td></td><td></td><td></td><td></td><td></td></tr> <tr><td>R78</td><td>X</td><td></td><td></td><td></td><td></td><td></td><td></td><td></td><td></td><td></td><td></td><td></td><td></td><td></td><td></td><td></td><td></td><td></td><td></td><td></td><td></td><td></td><td></td><td></td><td></td><td></td><td></td></tr> <tr><td>R79</td><td>X</td><td></td><td></td><td></td><td></td><td></td><td></td><td></td><td></td><td></td><td></td><td></td><td></td><td></td><td></td><td></td><td></td><td></td><td></td><td></td><td></td><td></td><td></td><td></td><td></td><td></td><td></td></tr> <tr><td>R80</td><td>X</td><td></td><td></td><td></td><td></td><td></td><td></td><td></td><td></td><td></td><td></td><td></td><td></td><td></td><td></td><td></td><td></td><td></td><td></td><td></td><td></td><td></td><td></td><td></td><td></td><td></td><td></td></tr> <tr><td>R81</td><td>X</td><td></td><td></td><td></td><td></td><td></td><td></td><td></td><td></td><td></td><td></td><td></td><td></td><td></td><td></td><td></td><td></td><td></td><td></td><td></td><td></td><td></td><td></td><td></td><td></td><td></td><td></td></tr> <tr><td>R82</td><td>X</td><td></td><td></td><td></td><td></td><td></td><td></td><td></td><td></td><td></td><td></td><td></td><td></td><td></td><td></td><td></td><td></td><td></td><td></td><td></td><td></td><td></td><td></td><td></td><td></td><td></td><td></td></tr> <tr><td>R83</td><td>X</td><td></td><td></td><td></td><td></td><td></td><td></td><td></td><td></td><td></td><td></td><td></td><td></td><td></td><td></td><td></td><td></td><td></td><td></td><td></td><td></td><td></td><td></td><td></td><td></td><td></td><td></td></tr> <tr><td>R84</td><td>X</td><td></td><td></td><td></td><td></td><td></td><td></td><td></td><td></td><td></td><td></td><td></td><td></td><td></td><td></td><td></td><td></td><td></td><td></td><td></td><td></td><td></td><td></td><td></td><td></td><td></td><td></td></tr> <tr><td>R85</td><td>X</td><td></td><td></td><td></td><td></td><td></td><td></td><td></td><td></td><td></td><td></td><td></td><td></td><td></td><td></td><td></td><td></td><td></td><td></td><td></td><td></td><td></td><td></td><td></td><td></td><td></td><td></td></tr> <tr><td>R86</td><td>X</td><td></td><td></td><td></td><td></td><td></td><td></td><td></td><td></td><td></td><td></td><td></td><td></td><td></td><td></td><td></td><td></td><td></td><td></td><td></td><td></td><td></td><td></td><td></td><td></td><td></td><td></td></tr> <tr><td>R87</td><td>X</td><td></td><td></td><td></td><td></td><td></td><td></td><td></td><td></td><td></td><td></td><td></td><td></td><td></td><td></td><td></td><td></td><td></td><td></td><td></td><td></td><td></td><td></td><td></td><td></td><td></td><td></td></tr> <tr><td>R88</td><td>X</td><td></td><td></td><td></td><td></td><td></td><td></td><td></td><td></td><td></td><td></td><td></td><td></td><td></td><td></td><td></td><td></td><td></td><td></td><td></td><td></td><td></td><td></td><td></td><td></td><td></td><td></td></tr> <tr><td>R89</td><td>X</td><td></td><td></td><td></td><td></td><td></td><td></td><td></td><td></td><td></td><td></td><td></td><td></td><td></td><td></td><td></td><td></td><td></td><td></td><td></td><td></td><td></td><td></td><td></td><td></td><td></td><td></td></tr> <tr><td>R90</td><td>X</td><td></td><td></td><td></td><td></td><td></td><td></td><td></td><td></td><td></td><td></td><td></td><td></td><td></td><td></td><td></td><td></td><td></td><td></td><td></td><td></td><td></td><td></td><td></td><td></td><td></td><td></td></tr> <tr><td>R91</td><td>X</td><td></td><td></td><td></td><td></td><td></td><td></td><td></td><td></td><td></td><td></td><td></td><td></td><td></td><td></td><td></td><td></td><td></td><td></td><td></td><td></td><td></td><td></td><td></td><td></td><td></td><td></td></tr> <tr><td>R92</td><td>X</td><td></td><td></td><td></td><td></td><td></td><td></td><td></td><td></td><td></td><td></td><td></td><td></td><td></td><td></td><td></td><td></td><td></td><td></td><td></td><td></td><td></td><td></td><td></td><td></td><td></td><td></td></tr> <tr><td>R93</td><td>X</td><td></td><td></td><td></td><td></td><td></td><td></td><td></td><td></td><td></td><td></td><td></td><td></td><td></td><td></td><td></td><td></td><td></td><td></td><td></td><td></td><td></td><td></td><td></td><td></td><td></td><td></td></tr> <tr><td>R94</td><td>X</td><td></td><td></td><td></td><td></td><td></td><td></td><td></td><td></td><td></td><td></td><td></td><td></td><td></td><td></td><td></td><td></td><td></td><td></td><td></td><td></td><td></td><td></td><td></td><td></td><td></td><td></td></tr> <tr><td>R95</td><td>X</td><td></td><td></td><td></td><td></td><td></td><td></td><td></td><td></td><td></td><td></td><td></td><td></td><td></td><td></td><td></td><td></td><td></td><td></td><td></td><td></td><td></td><td></td><td></td><td></td><td></td><td></td></tr> <tr><td>R96</td><td>X</td><td></td><td></td><td></td><td></td><td></td><td></td><td></td><td></td><td></td><td></td><td></td><td></td><td></td><td></td><td></td><td></td><td></td><td></td><td></td><td></td><td></td><td></td><td></td><td></td><td></td><td></td></tr> <tr><td>R97</td><td>X</td><td></td><td></td><td></td><td></td><td></td><td></td><td></td><td></td><td></td><td></td><td></td><td></td><td></td><td></td><td></td><td></td><td></td><td></td><td></td><td></td><td></td><td></td><td></td><td></td><td></td><td></td></tr> <tr><td>R98</td><td>X</td><td></td><td></td><td></td><td></td><td></td><td></td><td></td><td></td><td></td><td></td><td></td><td></td><td></td><td></td><td></td><td></td><td></td><td></td><td></td><td></td><td></td><td></td><td></td><td></td><td></td><td></td></tr> <tr><td>R99</td><td>X</td><td></td><td></td><td></td><td></td><td></td><td></td><td></td><td></td><td></td><td></td><td></td><td></td><td></td><td></td><td></td><td></td><td></td><td></td><td></td><td></td><td></td><td></td><td></td><td></td><td></td><td></td></tr> <tr><td>R100</td><td>X</td><td></td><td></td><td></td><td></td><td></td><td></td><td></td><td></td><td></td><td></td><td></td><td></td><td></td><td></td><td></td><td></td><td></td><td></td><td></td><td></td><td></td><td></td><td></td><td></td><td></td><td></td></tr> </tbody> </table>				MODEL #	1260-160A	1260-160B	1260-160C	1260-160D	1260-160E	1260-160F	1260-160G	1260-160H	1260-160I	1260-160J	1260-160K	1260-160L	1260-160M	1260-160N	1260-160O	1260-160P	1260-160Q	1260-160R	1260-160S	1260-160T	1260-160U	1260-160V	1260-160W	1260-160X	1260-160Y	1260-160Z	R31	X																											R32	X																											R33	X																											R34	X																											R35	X																											R36	X																											R37	X																											R38	X																											R39	X																											R40	X																											R41	X																											R42	X																											R43	X																											R44	X																											R45	X																											R46	X																											R47	X																											R48	X																											R49	X																											R50	X																											R51	X																											R52	X																											R53	X																											R54	X																											R55	X																											R56	X																											R57	X																											R58	X																											R59	X																											R60	X																											R61	X																											R62	X																											R63	X																											R64	X																											R65	X																											R66	X																											R67	X																											R68	X																											R69	X																											R70	X																											R71	X																											R72	X																											R73	X																											R74	X																											R75	X																											R76	X																											R77	X																											R78	X																											R79	X																											R80	X																											R81	X																											R82	X																											R83	X																											R84	X																											R85	X																											R86	X																											R87	X																											R88	X																											R89	X																											R90	X																											R91	X																											R92	X																											R93	X																											R94	X																											R95	X																											R96	X																											R97	X																											R98	X																											R99	X																											R100	X																										
MODEL #	1260-160A	1260-160B	1260-160C	1260-160D	1260-160E	1260-160F	1260-160G	1260-160H	1260-160I	1260-160J	1260-160K	1260-160L	1260-160M	1260-160N	1260-160O	1260-160P	1260-160Q	1260-160R	1260-160S	1260-160T	1260-160U	1260-160V	1260-160W	1260-160X	1260-160Y	1260-160Z																																																																																																																																																																																																																																																																																																																																																																																																																																																																																																																																																																																																																																																																																																																																																																																																																																																																																																																																																																																																																																																																																																																																																																																																																																																																																																																																																																																																																																																																																																																																																																																																																																																																																																																																																																																																																																																																																																																																																																																																																																												
R31	X																																																																																																																																																																																																																																																																																																																																																																																																																																																																																																																																																																																																																																																																																																																																																																																																																																																																																																																																																																																																																																																																																																																																																																																																																																																																																																																																																																																																																																																																																																																																																																																																																																																																																																																																																																																																																																																																																																																																																																																																																																																																					
R32	X																																																																																																																																																																																																																																																																																																																																																																																																																																																																																																																																																																																																																																																																																																																																																																																																																																																																																																																																																																																																																																																																																																																																																																																																																																																																																																																																																																																																																																																																																																																																																																																																																																																																																																																																																																																																																																																																																																																																																																																																																																																																					
R33	X																																																																																																																																																																																																																																																																																																																																																																																																																																																																																																																																																																																																																																																																																																																																																																																																																																																																																																																																																																																																																																																																																																																																																																																																																																																																																																																																																																																																																																																																																																																																																																																																																																																																																																																																																																																																																																																																																																																																																																																																																																																																					
R34	X																																																																																																																																																																																																																																																																																																																																																																																																																																																																																																																																																																																																																																																																																																																																																																																																																																																																																																																																																																																																																																																																																																																																																																																																																																																																																																																																																																																																																																																																																																																																																																																																																																																																																																																																																																																																																																																																																																																																																																																																																																																																					
R35	X																																																																																																																																																																																																																																																																																																																																																																																																																																																																																																																																																																																																																																																																																																																																																																																																																																																																																																																																																																																																																																																																																																																																																																																																																																																																																																																																																																																																																																																																																																																																																																																																																																																																																																																																																																																																																																																																																																																																																																																																																																																																					
R36	X																																																																																																																																																																																																																																																																																																																																																																																																																																																																																																																																																																																																																																																																																																																																																																																																																																																																																																																																																																																																																																																																																																																																																																																																																																																																																																																																																																																																																																																																																																																																																																																																																																																																																																																																																																																																																																																																																																																																																																																																																																																																					
R37	X																																																																																																																																																																																																																																																																																																																																																																																																																																																																																																																																																																																																																																																																																																																																																																																																																																																																																																																																																																																																																																																																																																																																																																																																																																																																																																																																																																																																																																																																																																																																																																																																																																																																																																																																																																																																																																																																																																																																																																																																																																																																					
R38	X																																																																																																																																																																																																																																																																																																																																																																																																																																																																																																																																																																																																																																																																																																																																																																																																																																																																																																																																																																																																																																																																																																																																																																																																																																																																																																																																																																																																																																																																																																																																																																																																																																																																																																																																																																																																																																																																																																																																																																																																																																																																					
R39	X																																																																																																																																																																																																																																																																																																																																																																																																																																																																																																																																																																																																																																																																																																																																																																																																																																																																																																																																																																																																																																																																																																																																																																																																																																																																																																																																																																																																																																																																																																																																																																																																																																																																																																																																																																																																																																																																																																																																																																																																																																																																					
R40	X																																																																																																																																																																																																																																																																																																																																																																																																																																																																																																																																																																																																																																																																																																																																																																																																																																																																																																																																																																																																																																																																																																																																																																																																																																																																																																																																																																																																																																																																																																																																																																																																																																																																																																																																																																																																																																																																																																																																																																																																																																																																					
R41	X																																																																																																																																																																																																																																																																																																																																																																																																																																																																																																																																																																																																																																																																																																																																																																																																																																																																																																																																																																																																																																																																																																																																																																																																																																																																																																																																																																																																																																																																																																																																																																																																																																																																																																																																																																																																																																																																																																																																																																																																																																																																					
R42	X																																																																																																																																																																																																																																																																																																																																																																																																																																																																																																																																																																																																																																																																																																																																																																																																																																																																																																																																																																																																																																																																																																																																																																																																																																																																																																																																																																																																																																																																																																																																																																																																																																																																																																																																																																																																																																																																																																																																																																																																																																																																					
R43	X																																																																																																																																																																																																																																																																																																																																																																																																																																																																																																																																																																																																																																																																																																																																																																																																																																																																																																																																																																																																																																																																																																																																																																																																																																																																																																																																																																																																																																																																																																																																																																																																																																																																																																																																																																																																																																																																																																																																																																																																																																																																					
R44	X																																																																																																																																																																																																																																																																																																																																																																																																																																																																																																																																																																																																																																																																																																																																																																																																																																																																																																																																																																																																																																																																																																																																																																																																																																																																																																																																																																																																																																																																																																																																																																																																																																																																																																																																																																																																																																																																																																																																																																																																																																																																					
R45	X																																																																																																																																																																																																																																																																																																																																																																																																																																																																																																																																																																																																																																																																																																																																																																																																																																																																																																																																																																																																																																																																																																																																																																																																																																																																																																																																																																																																																																																																																																																																																																																																																																																																																																																																																																																																																																																																																																																																																																																																																																																																					
R46	X																																																																																																																																																																																																																																																																																																																																																																																																																																																																																																																																																																																																																																																																																																																																																																																																																																																																																																																																																																																																																																																																																																																																																																																																																																																																																																																																																																																																																																																																																																																																																																																																																																																																																																																																																																																																																																																																																																																																																																																																																																																																					
R47	X																																																																																																																																																																																																																																																																																																																																																																																																																																																																																																																																																																																																																																																																																																																																																																																																																																																																																																																																																																																																																																																																																																																																																																																																																																																																																																																																																																																																																																																																																																																																																																																																																																																																																																																																																																																																																																																																																																																																																																																																																																																																					
R48	X																																																																																																																																																																																																																																																																																																																																																																																																																																																																																																																																																																																																																																																																																																																																																																																																																																																																																																																																																																																																																																																																																																																																																																																																																																																																																																																																																																																																																																																																																																																																																																																																																																																																																																																																																																																																																																																																																																																																																																																																																																																																					
R49	X																																																																																																																																																																																																																																																																																																																																																																																																																																																																																																																																																																																																																																																																																																																																																																																																																																																																																																																																																																																																																																																																																																																																																																																																																																																																																																																																																																																																																																																																																																																																																																																																																																																																																																																																																																																																																																																																																																																																																																																																																																																																					
R50	X																																																																																																																																																																																																																																																																																																																																																																																																																																																																																																																																																																																																																																																																																																																																																																																																																																																																																																																																																																																																																																																																																																																																																																																																																																																																																																																																																																																																																																																																																																																																																																																																																																																																																																																																																																																																																																																																																																																																																																																																																																																																					
R51	X																																																																																																																																																																																																																																																																																																																																																																																																																																																																																																																																																																																																																																																																																																																																																																																																																																																																																																																																																																																																																																																																																																																																																																																																																																																																																																																																																																																																																																																																																																																																																																																																																																																																																																																																																																																																																																																																																																																																																																																																																																																																					
R52	X																																																																																																																																																																																																																																																																																																																																																																																																																																																																																																																																																																																																																																																																																																																																																																																																																																																																																																																																																																																																																																																																																																																																																																																																																																																																																																																																																																																																																																																																																																																																																																																																																																																																																																																																																																																																																																																																																																																																																																																																																																																																					
R53	X																																																																																																																																																																																																																																																																																																																																																																																																																																																																																																																																																																																																																																																																																																																																																																																																																																																																																																																																																																																																																																																																																																																																																																																																																																																																																																																																																																																																																																																																																																																																																																																																																																																																																																																																																																																																																																																																																																																																																																																																																																																																					
R54	X																																																																																																																																																																																																																																																																																																																																																																																																																																																																																																																																																																																																																																																																																																																																																																																																																																																																																																																																																																																																																																																																																																																																																																																																																																																																																																																																																																																																																																																																																																																																																																																																																																																																																																																																																																																																																																																																																																																																																																																																																																																																					
R55	X																																																																																																																																																																																																																																																																																																																																																																																																																																																																																																																																																																																																																																																																																																																																																																																																																																																																																																																																																																																																																																																																																																																																																																																																																																																																																																																																																																																																																																																																																																																																																																																																																																																																																																																																																																																																																																																																																																																																																																																																																																																																					
R56	X																																																																																																																																																																																																																																																																																																																																																																																																																																																																																																																																																																																																																																																																																																																																																																																																																																																																																																																																																																																																																																																																																																																																																																																																																																																																																																																																																																																																																																																																																																																																																																																																																																																																																																																																																																																																																																																																																																																																																																																																																																																																					
R57	X																																																																																																																																																																																																																																																																																																																																																																																																																																																																																																																																																																																																																																																																																																																																																																																																																																																																																																																																																																																																																																																																																																																																																																																																																																																																																																																																																																																																																																																																																																																																																																																																																																																																																																																																																																																																																																																																																																																																																																																																																																																																					
R58	X																																																																																																																																																																																																																																																																																																																																																																																																																																																																																																																																																																																																																																																																																																																																																																																																																																																																																																																																																																																																																																																																																																																																																																																																																																																																																																																																																																																																																																																																																																																																																																																																																																																																																																																																																																																																																																																																																																																																																																																																																																																																					
R59	X																																																																																																																																																																																																																																																																																																																																																																																																																																																																																																																																																																																																																																																																																																																																																																																																																																																																																																																																																																																																																																																																																																																																																																																																																																																																																																																																																																																																																																																																																																																																																																																																																																																																																																																																																																																																																																																																																																																																																																																																																																																																					
R60	X																																																																																																																																																																																																																																																																																																																																																																																																																																																																																																																																																																																																																																																																																																																																																																																																																																																																																																																																																																																																																																																																																																																																																																																																																																																																																																																																																																																																																																																																																																																																																																																																																																																																																																																																																																																																																																																																																																																																																																																																																																																																					
R61	X																																																																																																																																																																																																																																																																																																																																																																																																																																																																																																																																																																																																																																																																																																																																																																																																																																																																																																																																																																																																																																																																																																																																																																																																																																																																																																																																																																																																																																																																																																																																																																																																																																																																																																																																																																																																																																																																																																																																																																																																																																																																					
R62	X																																																																																																																																																																																																																																																																																																																																																																																																																																																																																																																																																																																																																																																																																																																																																																																																																																																																																																																																																																																																																																																																																																																																																																																																																																																																																																																																																																																																																																																																																																																																																																																																																																																																																																																																																																																																																																																																																																																																																																																																																																																																					
R63	X																																																																																																																																																																																																																																																																																																																																																																																																																																																																																																																																																																																																																																																																																																																																																																																																																																																																																																																																																																																																																																																																																																																																																																																																																																																																																																																																																																																																																																																																																																																																																																																																																																																																																																																																																																																																																																																																																																																																																																																																																																																																					
R64	X																																																																																																																																																																																																																																																																																																																																																																																																																																																																																																																																																																																																																																																																																																																																																																																																																																																																																																																																																																																																																																																																																																																																																																																																																																																																																																																																																																																																																																																																																																																																																																																																																																																																																																																																																																																																																																																																																																																																																																																																																																																																					
R65	X																																																																																																																																																																																																																																																																																																																																																																																																																																																																																																																																																																																																																																																																																																																																																																																																																																																																																																																																																																																																																																																																																																																																																																																																																																																																																																																																																																																																																																																																																																																																																																																																																																																																																																																																																																																																																																																																																																																																																																																																																																																																					
R66	X																																																																																																																																																																																																																																																																																																																																																																																																																																																																																																																																																																																																																																																																																																																																																																																																																																																																																																																																																																																																																																																																																																																																																																																																																																																																																																																																																																																																																																																																																																																																																																																																																																																																																																																																																																																																																																																																																																																																																																																																																																																																					
R67	X																																																																																																																																																																																																																																																																																																																																																																																																																																																																																																																																																																																																																																																																																																																																																																																																																																																																																																																																																																																																																																																																																																																																																																																																																																																																																																																																																																																																																																																																																																																																																																																																																																																																																																																																																																																																																																																																																																																																																																																																																																																																					
R68	X																																																																																																																																																																																																																																																																																																																																																																																																																																																																																																																																																																																																																																																																																																																																																																																																																																																																																																																																																																																																																																																																																																																																																																																																																																																																																																																																																																																																																																																																																																																																																																																																																																																																																																																																																																																																																																																																																																																																																																																																																																																																					
R69	X																																																																																																																																																																																																																																																																																																																																																																																																																																																																																																																																																																																																																																																																																																																																																																																																																																																																																																																																																																																																																																																																																																																																																																																																																																																																																																																																																																																																																																																																																																																																																																																																																																																																																																																																																																																																																																																																																																																																																																																																																																																																					
R70	X																																																																																																																																																																																																																																																																																																																																																																																																																																																																																																																																																																																																																																																																																																																																																																																																																																																																																																																																																																																																																																																																																																																																																																																																																																																																																																																																																																																																																																																																																																																																																																																																																																																																																																																																																																																																																																																																																																																																																																																																																																																																					
R71	X																																																																																																																																																																																																																																																																																																																																																																																																																																																																																																																																																																																																																																																																																																																																																																																																																																																																																																																																																																																																																																																																																																																																																																																																																																																																																																																																																																																																																																																																																																																																																																																																																																																																																																																																																																																																																																																																																																																																																																																																																																																																					
R72	X																																																																																																																																																																																																																																																																																																																																																																																																																																																																																																																																																																																																																																																																																																																																																																																																																																																																																																																																																																																																																																																																																																																																																																																																																																																																																																																																																																																																																																																																																																																																																																																																																																																																																																																																																																																																																																																																																																																																																																																																																																																																					
R73	X																																																																																																																																																																																																																																																																																																																																																																																																																																																																																																																																																																																																																																																																																																																																																																																																																																																																																																																																																																																																																																																																																																																																																																																																																																																																																																																																																																																																																																																																																																																																																																																																																																																																																																																																																																																																																																																																																																																																																																																																																																																																					
R74	X																																																																																																																																																																																																																																																																																																																																																																																																																																																																																																																																																																																																																																																																																																																																																																																																																																																																																																																																																																																																																																																																																																																																																																																																																																																																																																																																																																																																																																																																																																																																																																																																																																																																																																																																																																																																																																																																																																																																																																																																																																																																					
R75	X																																																																																																																																																																																																																																																																																																																																																																																																																																																																																																																																																																																																																																																																																																																																																																																																																																																																																																																																																																																																																																																																																																																																																																																																																																																																																																																																																																																																																																																																																																																																																																																																																																																																																																																																																																																																																																																																																																																																																																																																																																																																					
R76	X																																																																																																																																																																																																																																																																																																																																																																																																																																																																																																																																																																																																																																																																																																																																																																																																																																																																																																																																																																																																																																																																																																																																																																																																																																																																																																																																																																																																																																																																																																																																																																																																																																																																																																																																																																																																																																																																																																																																																																																																																																																																					
R77	X																																																																																																																																																																																																																																																																																																																																																																																																																																																																																																																																																																																																																																																																																																																																																																																																																																																																																																																																																																																																																																																																																																																																																																																																																																																																																																																																																																																																																																																																																																																																																																																																																																																																																																																																																																																																																																																																																																																																																																																																																																																																					
R78	X																																																																																																																																																																																																																																																																																																																																																																																																																																																																																																																																																																																																																																																																																																																																																																																																																																																																																																																																																																																																																																																																																																																																																																																																																																																																																																																																																																																																																																																																																																																																																																																																																																																																																																																																																																																																																																																																																																																																																																																																																																																																					
R79	X																																																																																																																																																																																																																																																																																																																																																																																																																																																																																																																																																																																																																																																																																																																																																																																																																																																																																																																																																																																																																																																																																																																																																																																																																																																																																																																																																																																																																																																																																																																																																																																																																																																																																																																																																																																																																																																																																																																																																																																																																																																																					
R80	X																																																																																																																																																																																																																																																																																																																																																																																																																																																																																																																																																																																																																																																																																																																																																																																																																																																																																																																																																																																																																																																																																																																																																																																																																																																																																																																																																																																																																																																																																																																																																																																																																																																																																																																																																																																																																																																																																																																																																																																																																																																																					
R81	X																																																																																																																																																																																																																																																																																																																																																																																																																																																																																																																																																																																																																																																																																																																																																																																																																																																																																																																																																																																																																																																																																																																																																																																																																																																																																																																																																																																																																																																																																																																																																																																																																																																																																																																																																																																																																																																																																																																																																																																																																																																																					
R82	X																																																																																																																																																																																																																																																																																																																																																																																																																																																																																																																																																																																																																																																																																																																																																																																																																																																																																																																																																																																																																																																																																																																																																																																																																																																																																																																																																																																																																																																																																																																																																																																																																																																																																																																																																																																																																																																																																																																																																																																																																																																																					
R83	X																																																																																																																																																																																																																																																																																																																																																																																																																																																																																																																																																																																																																																																																																																																																																																																																																																																																																																																																																																																																																																																																																																																																																																																																																																																																																																																																																																																																																																																																																																																																																																																																																																																																																																																																																																																																																																																																																																																																																																																																																																																																					
R84	X																																																																																																																																																																																																																																																																																																																																																																																																																																																																																																																																																																																																																																																																																																																																																																																																																																																																																																																																																																																																																																																																																																																																																																																																																																																																																																																																																																																																																																																																																																																																																																																																																																																																																																																																																																																																																																																																																																																																																																																																																																																																					
R85	X																																																																																																																																																																																																																																																																																																																																																																																																																																																																																																																																																																																																																																																																																																																																																																																																																																																																																																																																																																																																																																																																																																																																																																																																																																																																																																																																																																																																																																																																																																																																																																																																																																																																																																																																																																																																																																																																																																																																																																																																																																																																					
R86	X																																																																																																																																																																																																																																																																																																																																																																																																																																																																																																																																																																																																																																																																																																																																																																																																																																																																																																																																																																																																																																																																																																																																																																																																																																																																																																																																																																																																																																																																																																																																																																																																																																																																																																																																																																																																																																																																																																																																																																																																																																																																					
R87	X																																																																																																																																																																																																																																																																																																																																																																																																																																																																																																																																																																																																																																																																																																																																																																																																																																																																																																																																																																																																																																																																																																																																																																																																																																																																																																																																																																																																																																																																																																																																																																																																																																																																																																																																																																																																																																																																																																																																																																																																																																																																					
R88	X																																																																																																																																																																																																																																																																																																																																																																																																																																																																																																																																																																																																																																																																																																																																																																																																																																																																																																																																																																																																																																																																																																																																																																																																																																																																																																																																																																																																																																																																																																																																																																																																																																																																																																																																																																																																																																																																																																																																																																																																																																																																					
R89	X																																																																																																																																																																																																																																																																																																																																																																																																																																																																																																																																																																																																																																																																																																																																																																																																																																																																																																																																																																																																																																																																																																																																																																																																																																																																																																																																																																																																																																																																																																																																																																																																																																																																																																																																																																																																																																																																																																																																																																																																																																																																					
R90	X																																																																																																																																																																																																																																																																																																																																																																																																																																																																																																																																																																																																																																																																																																																																																																																																																																																																																																																																																																																																																																																																																																																																																																																																																																																																																																																																																																																																																																																																																																																																																																																																																																																																																																																																																																																																																																																																																																																																																																																																																																																																					
R91	X																																																																																																																																																																																																																																																																																																																																																																																																																																																																																																																																																																																																																																																																																																																																																																																																																																																																																																																																																																																																																																																																																																																																																																																																																																																																																																																																																																																																																																																																																																																																																																																																																																																																																																																																																																																																																																																																																																																																																																																																																																																																					
R92	X																																																																																																																																																																																																																																																																																																																																																																																																																																																																																																																																																																																																																																																																																																																																																																																																																																																																																																																																																																																																																																																																																																																																																																																																																																																																																																																																																																																																																																																																																																																																																																																																																																																																																																																																																																																																																																																																																																																																																																																																																																																																					
R93	X																																																																																																																																																																																																																																																																																																																																																																																																																																																																																																																																																																																																																																																																																																																																																																																																																																																																																																																																																																																																																																																																																																																																																																																																																																																																																																																																																																																																																																																																																																																																																																																																																																																																																																																																																																																																																																																																																																																																																																																																																																																																					
R94	X																																																																																																																																																																																																																																																																																																																																																																																																																																																																																																																																																																																																																																																																																																																																																																																																																																																																																																																																																																																																																																																																																																																																																																																																																																																																																																																																																																																																																																																																																																																																																																																																																																																																																																																																																																																																																																																																																																																																																																																																																																																																					
R95	X																																																																																																																																																																																																																																																																																																																																																																																																																																																																																																																																																																																																																																																																																																																																																																																																																																																																																																																																																																																																																																																																																																																																																																																																																																																																																																																																																																																																																																																																																																																																																																																																																																																																																																																																																																																																																																																																																																																																																																																																																																																																					
R96	X																																																																																																																																																																																																																																																																																																																																																																																																																																																																																																																																																																																																																																																																																																																																																																																																																																																																																																																																																																																																																																																																																																																																																																																																																																																																																																																																																																																																																																																																																																																																																																																																																																																																																																																																																																																																																																																																																																																																																																																																																																																																					
R97	X																																																																																																																																																																																																																																																																																																																																																																																																																																																																																																																																																																																																																																																																																																																																																																																																																																																																																																																																																																																																																																																																																																																																																																																																																																																																																																																																																																																																																																																																																																																																																																																																																																																																																																																																																																																																																																																																																																																																																																																																																																																																					
R98	X																																																																																																																																																																																																																																																																																																																																																																																																																																																																																																																																																																																																																																																																																																																																																																																																																																																																																																																																																																																																																																																																																																																																																																																																																																																																																																																																																																																																																																																																																																																																																																																																																																																																																																																																																																																																																																																																																																																																																																																																																																																																					
R99	X																																																																																																																																																																																																																																																																																																																																																																																																																																																																																																																																																																																																																																																																																																																																																																																																																																																																																																																																																																																																																																																																																																																																																																																																																																																																																																																																																																																																																																																																																																																																																																																																																																																																																																																																																																																																																																																																																																																																																																																																																																																																					
R100	X																																																																																																																																																																																																																																																																																																																																																																																																																																																																																																																																																																																																																																																																																																																																																																																																																																																																																																																																																																																																																																																																																																																																																																																																																																																																																																																																																																																																																																																																																																																																																																																																																																																																																																																																																																																																																																																																																																																																																																																																																																																																					
D	C	B	A																																																																																																																																																																																																																																																																																																																																																																																																																																																																																																																																																																																																																																																																																																																																																																																																																																																																																																																																																																																																																																																																																																																																																																																																																																																																																																																																																																																																																																																																																																																																																																																																																																																																																																																																																																																																																																																																																																																																																																																																																																																																			
<p>COMPONENT USAGE</p>																																																																																																																																																																																																																																																																																																																																																																																																																																																																																																																																																																																																																																																																																																																																																																																																																																																																																																																																																																																																																																																																																																																																																																																																																																																																																																																																																																																																																																																																																																																																																																																																																																																																																																																																																																																																																																																																																																																																																																																																																																																																						
1	2	3	4																																																																																																																																																																																																																																																																																																																																																																																																																																																																																																																																																																																																																																																																																																																																																																																																																																																																																																																																																																																																																																																																																																																																																																																																																																																																																																																																																																																																																																																																																																																																																																																																																																																																																																																																																																																																																																																																																																																																																																																																																																																																			
D	C	B	A																																																																																																																																																																																																																																																																																																																																																																																																																																																																																																																																																																																																																																																																																																																																																																																																																																																																																																																																																																																																																																																																																																																																																																																																																																																																																																																																																																																																																																																																																																																																																																																																																																																																																																																																																																																																																																																																																																																																																																																																																																																																			

DWG. NO. 435175

SH. 2

REV. B

SIZE **B** CAGE CODE **21793** SCALE **NONE**

DWG NO. **435175** REV. **B**

30-Oct-2001 SHEET 2 OF 9

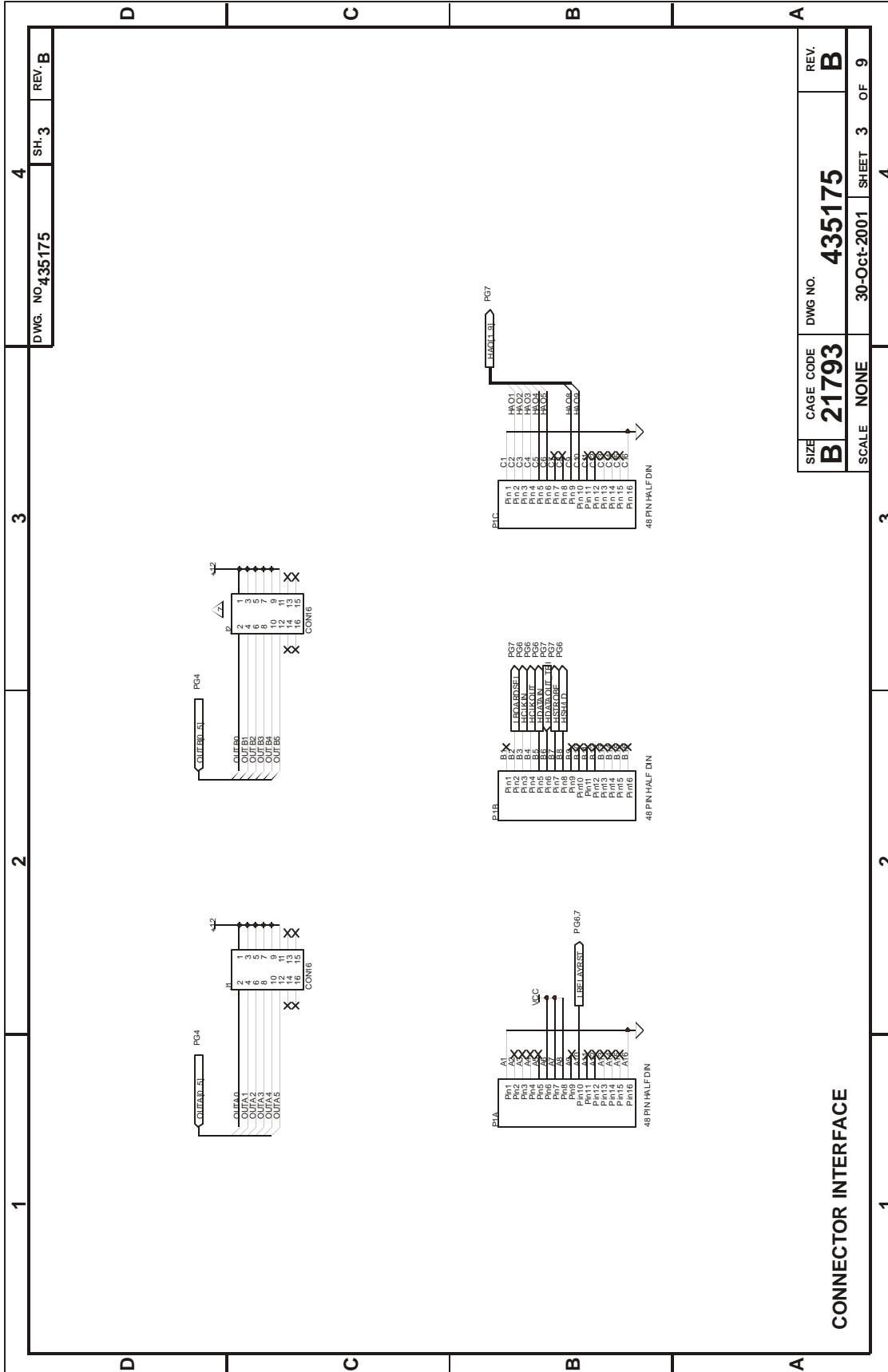

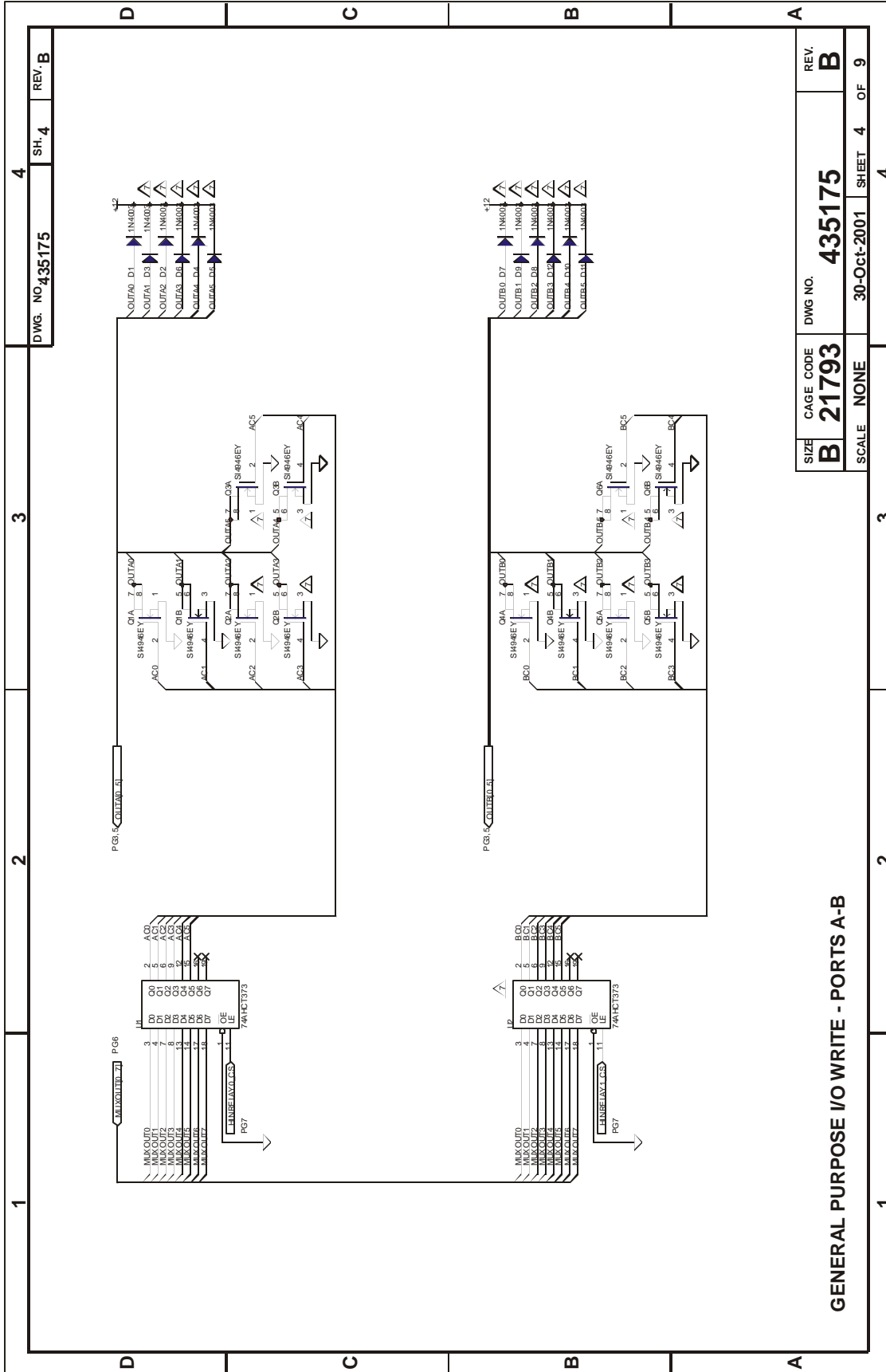

DWG. NO. 435175 SH. 4 REV. B

SIZE B CAGE CODE 21793 DWG NO. 435175 REV. B
SCALE NONE 30-Oct-2001 SHEET 4 OF 9

GENERAL PURPOSE I/O WRITE - PORTS A-B

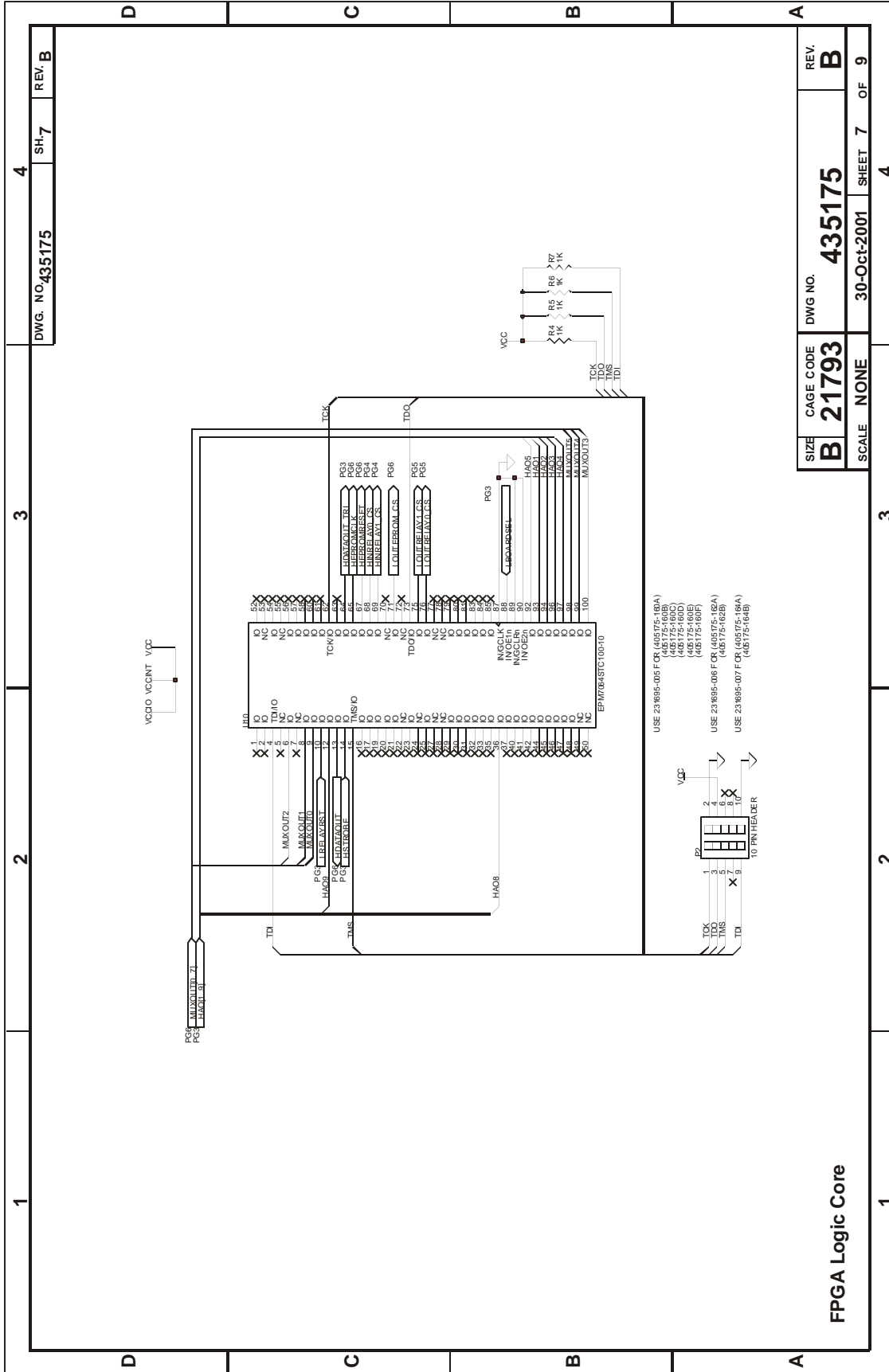

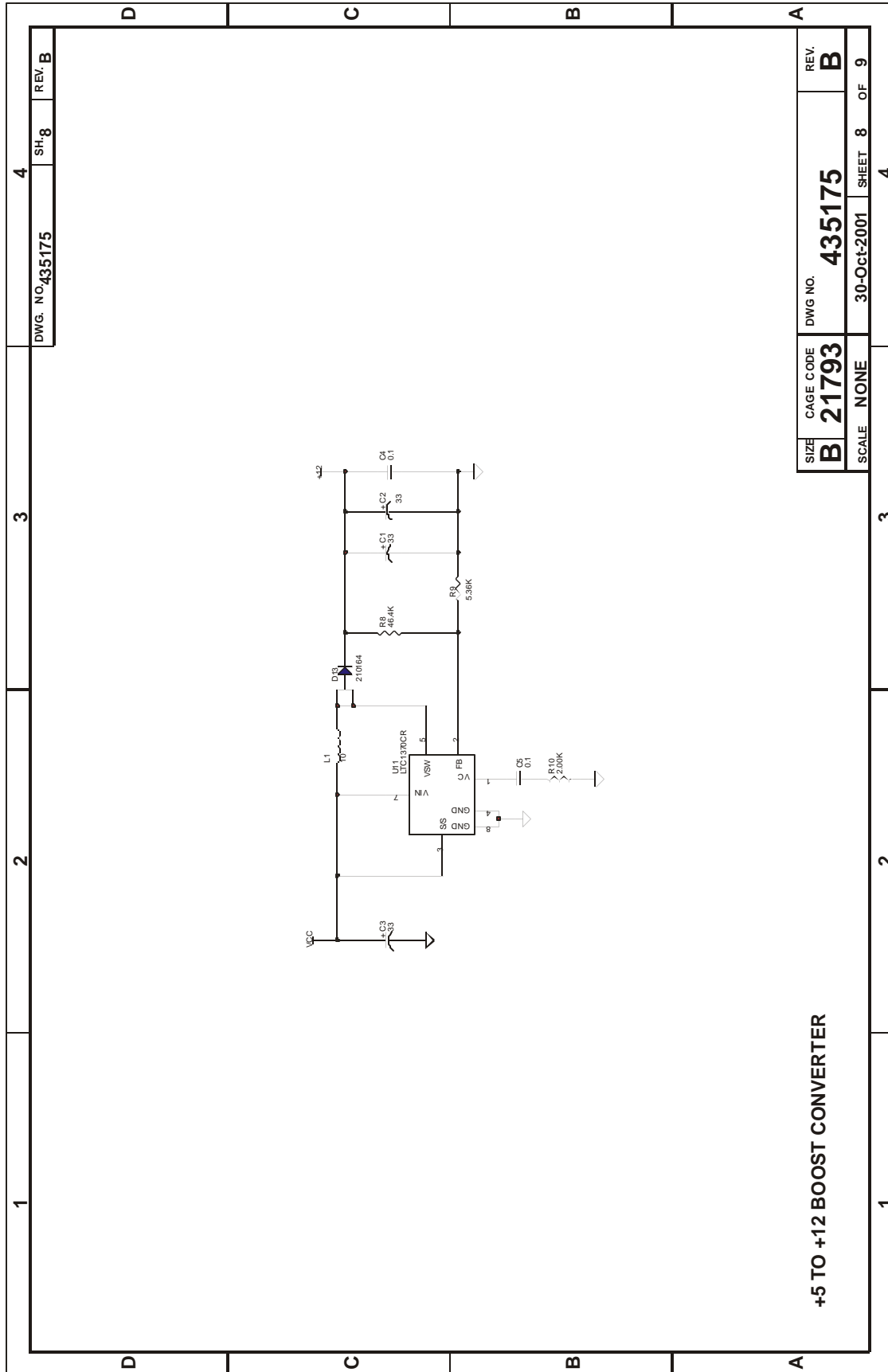

DWG. NO. 435175		SH-8	REV. B
4	3		4

SIZE	CAGE CODE	DWG NO.	REV.
B	21793	435175	B
SCALE	NONE	30-Oct-2001	SHEET 8 OF 9
1		2	3
1		2	3

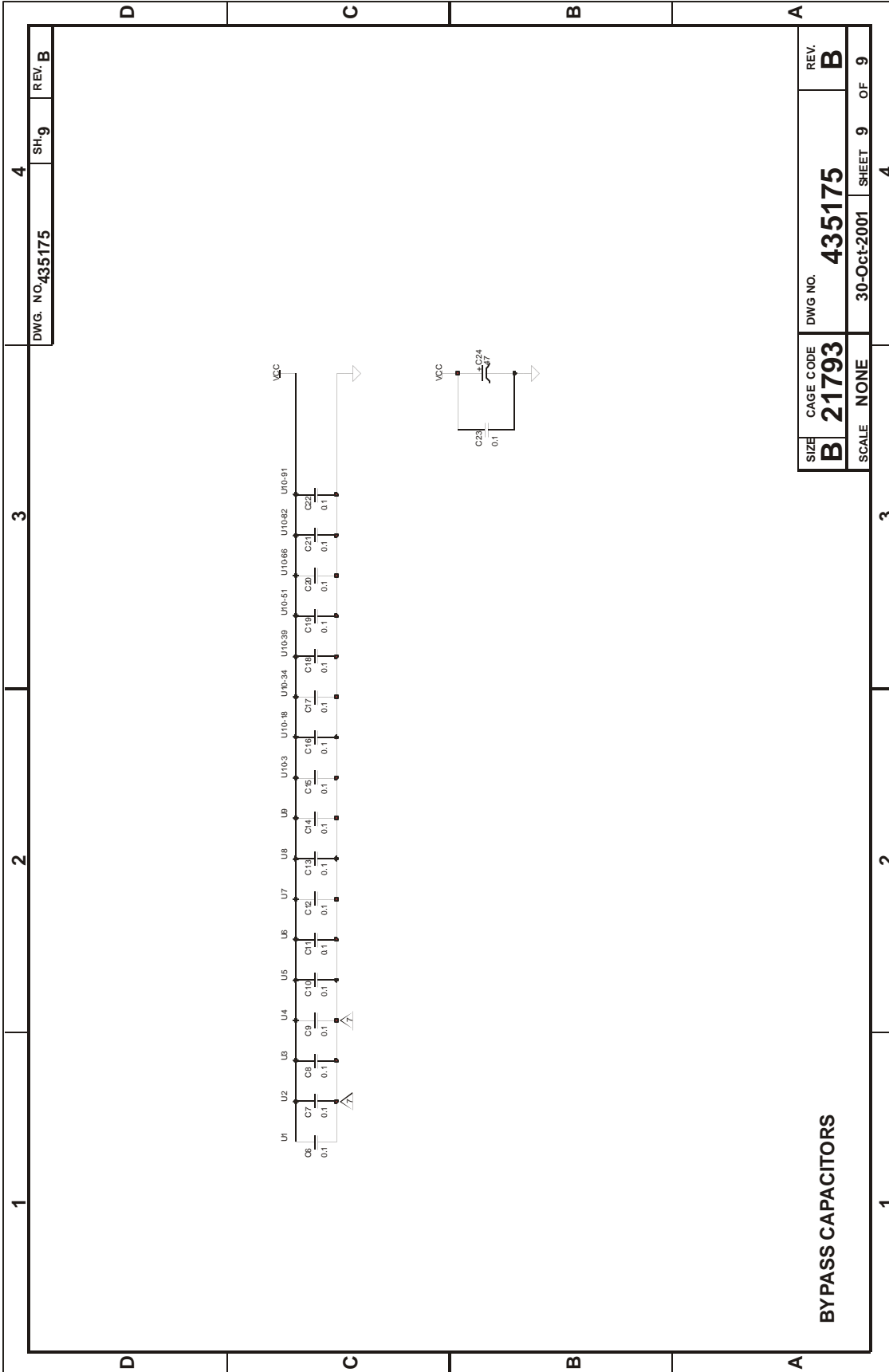

BYPASS CAPACITORS

SIZE	CAGE CODE	DWG NO.	REV.
B	21793	435175	B
SCALE	NONE	30-Oct-2001	SHEET 9 OF 9

Chapter 5

PARTS LIST

407767-001, 1260-162A, 1 RF TRANSFER SW	5-3
405175-162A, PCB ASSY, 1260-162A	5-4
407767-002, 1260-162B, 2 RF TRANSFER SW	5-5
405175-162B, PCB ASSY, 1260-162B.....	5-6

This page was left intentionally blank.

1260-162 User Manual

Assembly 407767-001
Description 1260-162A, 1 RF TRANSFER SW -E
EA

Low Level Code 00
Revision Date 2001-05-02
Revision A

#	Component	Description	UM	Qty Reqd	Txt
	405175-162A	PCB ASSY, 1260-162A	EA	1.000	
	980824-162	MANUAL, 1260-162	EA	1.000	

Assembly 405175-162A
 Description PCB ASSY, 1260-162A -N
 EA

Low Level Code 01
 Revision Date 2001-10-25
 Revision A

#	Component	Description	UM	Qty Reqd	Txt
1	050000-000	RSCH1-000.00H.06W005	EA	5.000	
2	050000-102	RSCH2-001.00K.06W005	EA	4.000	
3	050000-103	RSCH2-010.00K.06W005	EA	2.000	
4	050000-202	RSCH2-002.00K.06W005	EA	1.000	
5	050117-007	RSCH2-046.40K.10W001	EA	1.000	
6	050117-008	RSCH2-005.36K.10W001	EA	1.000	
9	080171	RSNW2-004.700K16P08R	EA	1.000	
10	080171-001	RSNW2-047.000K16P08R	EA	1.000	
13	100168-104	CPCH2-0100.0N0050V10%0805X7R	EA	18.000	
14	110260	CPTA3-0047.0U0016V20	EA	1.000	
15	130200	CPCH3-0033.040016V20	EA	3.000	
18	210153	DISLC-075.0V00.20A-1N4148	EA	1.000	
19	210154	DISPR-200.0V01.00A-1N4003	EA	1.000	
20	210164	DISHY-035.0V08.00A	EA	1.000	
23	231120	ICDIG-74HCT166-SHFT	EA	1.000	
24	231131	ICDIG-74HCT164-SHFT	EA	1.000	
25	231588-044	ICMEM-27C256-15-PLCC-A	EA	1.000	
26	231597	ICLIN-SI4946EY—SOIC	EA	1.000	
27	231598	ICDIG-74AHCT373-TSSOP	EA	2.000	
28	231603	ICDIG-74HCT393—SOIC	EA	2.000	
29	231605-006	ICPLA-EPM7064ST-TQFP	EA	1.000	
30	231649	ICLIN-1370—DD	EA	1.000	
32	310287	CKF1-OW010.0U20%P	EA	1.000	
34	310296	RLEM-2P2T12V0035	EA	1.000	
37	407785-001	CABLE ASSY,1260-162A	EA	1.000	
39	415175	PCB,1260-160,-162,-164	EA	1.000	
41	456919-001	PANEL,FRONT,1260-162A	EA	1.000	
48	601731	CON-PCB-PLG16PC.100D	EA	1.000	
49	601935	CON-PCB-PLG10PC.100D	EA	1.000	
50	602070	CON-PCB-PLG48PC.1003	EA	1.000	
54	610899	TIE-CA-LKG-.062-2.00	EA	2.000	
56	611323	CLP-CA-STD.N/ACN/A	EA	1.000	
57	611444	S1C-SBDR-M2.5X0.45X11	EA	4.000	
60	615016	S1M-PPANH002-56X.375	EA	4.000	
63	616403	S1MPFL9-M2.5X0.45X08	EA	2.000	
67	617041	NT1HEXM2.5-0.50-STL	EA	2.000	
70	617126	W1S002.165D.015T.088	EA	4.000	
71	617127	W1S004.202D.020T.115	EA	2.000	
75	921423	LABEL,CE MARKING	EA	1.000	

1260-162 User Manual

Assembly 407767-002
Description 1260-162B, 2 RF TRANSFER SW -E
EA

Low Level Code 00
Revision Date 2001-05-02
Revision A

#	Component	Description	UM	Qty Reqd	Txt
	405175-162B	PCB ASSY, 1260-162B	EA	1.000	
	980824-162	MANUAL, 1260-162	EA	1.000	

Assembly 405175-162B
 Description PCB ASSY, 1260-162B -N
 EA

Low Level Code 01
 Revision Date 2001-10-25
 Revision A

#	Component	Description	UM	Qty Reqd	Txt
1	050000-000	RSCH1-000.00H.06W005	EA	4.000	
2	050000-102	RSCH2-001.00K.06W005	EA	4.000	
3	050000-103	RSCH2-010.00K.06W005	EA	2.000	
4	050000-202	RSCH2-002.00K.06W005	EA	1.000	
5	050117-007	RSCH2-046.40K.10W001	EA	1.000	
6	050117-008	RSCH2-005.36K.10W001	EA	1.000	
9	080171	RSNW2-004.700K16P08R	EA	1.000	
10	080171-001	RSNW2-047.000K16P08R	EA	1.000	
13	100168-104	CPCH2-0100.0N0050V10%0805X7R	EA	18.000	
14	110260	CPTA3-0047.0U0016V20	EA	1.000	
15	130200	CPCH3-0033.040016V20	EA	3.000	
18	210153	DISLC-075.0V00.20A-1N4148	EA	2.000	
19	210154	DISPR-200.0V01.00A-1N4003	EA	2.000	
20	210164	DISHY-035.0V08.00A	EA	1.000	
23	231120	ICDIG-74HCT166-SHFT	EA	1.000	
24	231131	ICDIG-74HCT164-SHFT	EA	1.000	
25	231588-045	ICMEM-27C256-15-PLCC-B	EA	1.000	
26	231597	ICLIN-SI4946EY—SOIC	EA	1.000	
27	231598	ICDIG-74AHCT373-TSSOP	EA	2.000	
28	231603	ICDIG-74HCT393—SOIC	EA	2.000	
29	231605-006	ICPLA-EPM7064ST-TQFP	EA	1.000	
30	231649	ICLIN-1370—DD	EA	1.000	
32	310287	CKF1-OW010.0U20%P	EA	1.000	
34	310296	RLEM-2P2T12V0035	EA	2.000	
37	407785-002	CABLE ASSY,1260-162B	EA	1.000	
39	415175	PCB,1260-160,-162,-164	EA	1.000	
41	456919-002	PANEL,FRONT,1260-162B	EA	1.000	
48	601731	CON-PCB-PLG16PC.100D	EA	1.000	
49	601935	CON-PCB-PLG10PC.100D	EA	1.000	
50	602070	CON-PCB-PLG48PC.1003	EA	1.000	
54	610899	TIE-CA-LKG-.062-2.00	EA	3.000	
56	611323	CLP-CA-STD.N/ACN/A	EA	2.000	
57	611444	S1C-SBDR-M2.5X0.45X11	EA	4.000	
60	615016	S1M-PPANH002-56X.375	EA	8.000	
63	616403	S1MPFL9-M2.5X0.45X08	EA	2.000	
67	617041	NT1HEXM2.5-0.50-STL	EA	2.000	
70	617126	W1S002.165D.015T.088	EA	8.000	
71	617127	W1S004.202D.020T.115	EA	2.000	
75	921423	LABEL,CE MARKING	EA	1.000	

Chapter 6

PRODUCT SUPPORT

Product Support

Racal Instruments has a complete Service and Parts Department. If you need technical assistance or should it be necessary to return your product for repair or calibration, call 1-800-722-3262, or call 949-859-8999 and ask for Customer Support. You may also contact Customer Support via E-Mail at:

help_desk@racalstruments.com

If you require parts to repair the product at your facility, call 1-800-722-3262, or 949-859-8999 and ask for the Customer Service Department.

When sending your instrument in for repair, complete the form in the back of this manual. For worldwide support and the office closes to your facility, refer to the Support Offices section on the following page.

Reshipment Instructions

Use the original packing material when returning the chassis to Racal Instruments for servicing. The original shipping carton and the instrument's plastic foam will provide the necessary support for safe reshipment.

If the original packing material is unavailable, wrap the chassis in ESD shielding material and use foam to surround and protect the instrument.

Reship in either the original or a new shipping carton.

Support Offices

Racal Instruments, Inc.

4 Goodyear St., Irvine, CA 92618-2002
Tel: (800) 722-3262, FAX: (949) 859-7309

Racal Instruments, Ltd.

480 Bath Road, Slough, Berkshire, SL1 6BE, United Kingdom
Tel: +44 (0) 8706 080134; FAX: +44 (0) 1753 791290

Racal Systems Electronique S.A.

18 Avenue Dutartre, 78150 LeChesnay, France
Tel: +33 (1) 3923 2222; FAX: +33 (1) 3923 2225

Racal Systems Elettronica s.r.l.

Strada 2-Palazzo C4, 20090 Milanofiori Assago, Milan, Italy
Tel: +39 (02) 5750 1796; FAX +39 (02) 5750 1828

Racal Elektronik System GmbH.

Frankenforster Strasse 21, 51427 Bergisch Gladbach,
Germany
Tel:+49 2204 92220; FAX: +49 2204 21491

Racal Australia Pty. Ltd.

3 Powells Road, Brookvale, NSW 2100, Australia
Tel: +61 (2) 9936 7000, FAX: +61 (2) 9936 7036

Racal Electronics Pte. Ltd.

26 Ayer Rajah Crescent, 04-06/07 Ayer Rajah Industrial Estate,
Singapore 0513.
Tel: +65 7792200, FAX: +65 7785400

Racal Instruments, Ltd.

Unit 5, 25F., Mega Trade Center, No 1, Mei Wan Road, Tsuen
Wan, Hong Kong, PRC
Tel: +852 2405 5500, FAX: +852 2416 4335